

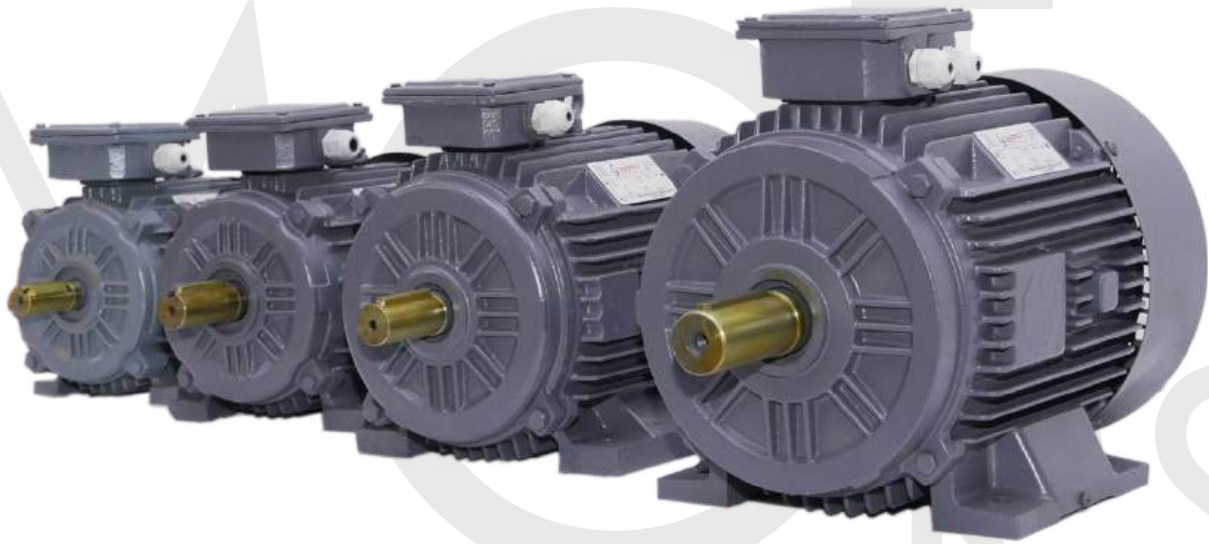

**POWERTEK EQUIPMENT CO THANE**



# **A.C. INDUCTION MOTORS**

**TEFC (TOTALLY ENCLOSED FAN COOLED)  
THREE PHASE & SINGLE PHASE SQUIRREL CAGE**



[www.powertekindia.com](http://www.powertekindia.com)

# THREE PHASE INDUCTION MOTORS



IE2 HIGH EFFICIENCY CAST IRON  
(FOOT MOUNTED)  
RANGE : 0.25HP to 50.0HP



IE2 HIGH EFFICIENCY CAST IRON  
(FLANGE MOUNTED)  
RANGE : 0.25HP to 50.0HP



IE2 HIGH EFFICIENCY ALUMINIUM BODY  
(FOOT MOUNTED)  
RANGE : 0.25HP to 2.0HP



IE2 HIGH EFFICIENCY ALUMINIUM BODY  
(FLANGE MOUNTED)  
RANGE : 0.25HP to 2.0HP



IE2 HIGH EFFICIENCY CAST IRON BODY  
(FOOT & FLANGE MOUNTED)  
(AC BRAKE MOTORS)  
RANGE : 0.25HP to 50.0HP



IE2 HIGH EFFICIENCY ALUMINIUM BODY  
(FOOT & FLANGE MOUNTED)  
(DC BRAKE MOTORS)  
RANGE : 0.25HP to 2.0HP

IS : 12615



IP55

CM/L-7600104914

CE IE2 | High Efficiency IE3 | Premium Efficiency

# ENERGY SAVING IE2 & IE3 MOTORS

AC Motors are suitable for a variety of industrial, domestic & other general purpose applications.

## TECHNICAL SPECIFICATION

- Voltage : Rated voltage < 1000V
- Output : Rated output 0.37kW to 90kW
- No of Poles : 2, 4 or 6 Poles
- Frame Dimensions : Meet frame size to output relation as covered in IS:1231
- Ambient Temperature : Designed for an ambient temperature not exceeding 50°C and altitude not exceeding 1000
- Balance Voltage : Designed for an ambient temperature not exceeding 50°C and altitude not exceeding 1000
- Degree of protection : Degree of protection Ip55
- Cooling Method : Method of cooling Ic411 in accordance with IS 6362/IEC 60034-6

## CONSTRUCTION FEATURES :

**Housing :** (Stator Frame) Cast Iron body with cooling ribs

**Rotor :** Core of Insulated Lamination with a high pressure die-cast Aluminum cage. The whole rotor assembly is dynamically balanced to ensure quiet and vibration free operation. Surface of rotor is protected by anti corrosion coating.

**Shaft :** Made from high carbon steel (ie. EN-8)

**Terminal Box :** Are located at right hand side of the drive end side, sealed against ingress of moisture. Also provided with conduit entry, Earthing terminal is fitted at the box-side.

High air flow external Bi-directional polypropylene fans assure low temperature rise to give an extended life of motor. Fan cowls are suitable gauge pressed steel construction, securely bolted to end shield of motor-body.

## WEIGHTS & SHIPPING DIMENSION :

FRAME	56	63	71	80	90S	90L	100L	112M	132S	132M	160M	160L	180M	180L	200L	225S	225M	250M	280S	280M	
Wt. (kg)	Gr.	5	8	11	17	19	23	37	58	85	94	140	167	202	220	298	365	410	435	550	600
	Nt.	4	7	10	16	18	22	35	45	60	70	100	135	180	190	260	325	365	390	490	540
BOX (cms)	L	24	24	28	32	38	38	45	55	65	65	80	80	90	90	95	97	97	110	123	123
	H	16	16	18	19	23	23	24	41	43	43	47	47	48	48	55	60	60	66	74	74
	W	22	22	24	27	29	29	34	41	50	50	58	58	60	60	73	73	73	75	80	80

## CABLE SIZE OF STANDARD MOTOR :

Frame Size	Max. Cable Size		Cable Entry Size	Terminal Stud Size
	DOL Starting	Star - D Starting		
56 - 71	3C X 2.5mm <sup>2</sup>	-	1 X 3/4"	M4
80 - 90 - 100	3C X 4.0mm <sup>2</sup>	-	1 X 3/4"	M4
132	3C X 10mm <sup>2</sup>	2 X 3C X 10mm <sup>2</sup>	2 X 1"	M5
160 - 180	3C X 35mm <sup>2</sup>	2 X 3C X 25mm <sup>2</sup>	2 X 1"	M8
200 - 225	3C X 120mm <sup>2</sup>	2 X 3C X 70mm <sup>2</sup>	2 X 2"	M8
250 - 280	3C X 240mm <sup>2</sup>	2 X 3C X 150mm <sup>2</sup>	2 X 2"	M10

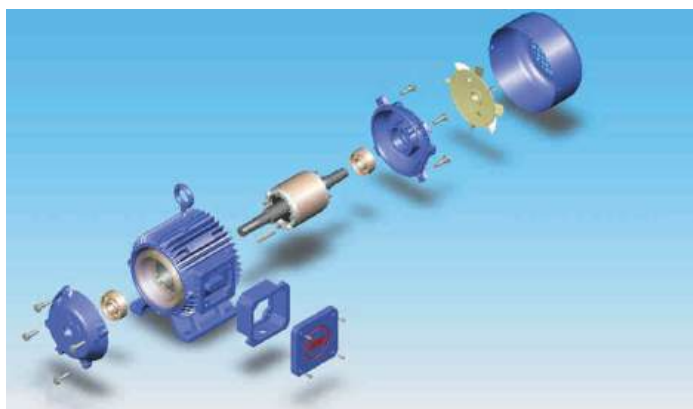
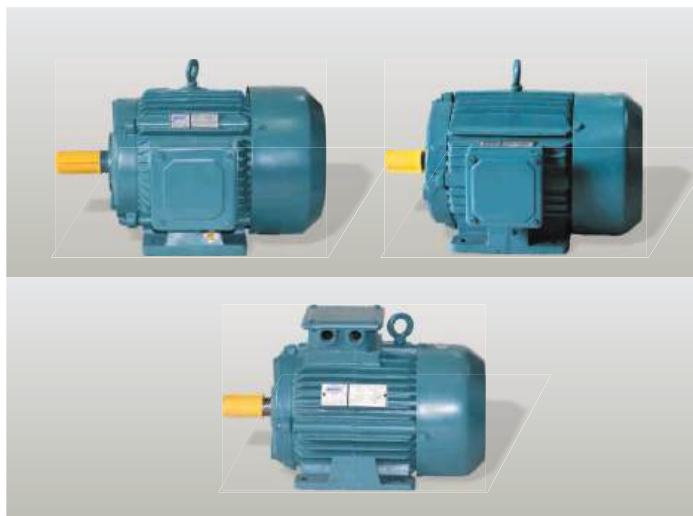

Frame Size	Bearing No.		Frame Size	Bearing No.	
Size	DE	NDE	Size	DE	NDE
71	6203ZZ	6203ZZ	132	6308ZZ	6307ZZ
80	6204ZZ	6204ZZ	160	6309ZZ	6309ZZ
90	6205ZZ	6204ZZ	180	6310ZZ	6310ZZ
100	6206ZZ	6205ZZ	200	6312	6312
112	6206ZZ	6206ZZ	225	6314	6314

# IE2

## TECHNICAL DETAILS

General performance cast iron motors  
 Technical data for totally enclosed squirrel  
 cage three phase motors

### 3000 RPM

Output kW	Frame Size	Speed RPM	Efficiency			Power factor cosφ	Current		Torque			Moment of inertia J=1/4GD <sup>2</sup> (Kgm <sup>2</sup> )	Weigh kg
			Full load 100%	3/4 load 75%	1/2 load 50%		I <sub>n</sub> A	I <sub>s</sub> / I <sub>n</sub>	T <sub>m</sub> / Nm	T <sub>1</sub> / T <sub>n</sub>	T <sub>s</sub> / T <sub>n</sub>		
0.37	71	2660	72.2	72.2	72.0	0.8	0.92	3.9	1.3	2.2	2.3	0.00039	11
0.55	71	2680	74.8	74.8	74.0	0.85	1.2	4.3	2	2.4	2.5	0.00051	11
0.75	80	2895	77.4	77.4	73.0	0.74	1.8	6.5	2.5	2.4	4.2	0.001	16
1.1	80	2870	79.6	79.6	78.0	0.80	2.4	6.5	3.7	2.7	3.5	0.0012	18
1.5	90	2900	81.3	81.3	79.9	0.86	3.0	6.5	4.9	2.5	2.6	0.00254	24
2.2	90	2885	83.2	83.2	82.2	0.87	4.2	7.0	7.3	1.9	2.5	0.0028	25
3.7	100	2905	85.5	85.5	85.0	0.86	7.0	7.0	12.2	2.9	3.2	0.00575	37
5.5	132	2865	87.0	87.0	85.8	0.86	10.2	7.0	18.3	2.0	2.7	0.01275	68
7.5	132	2890	88.1	88.1	86.3	0.84	14.1	7.0	24.8	2.0	3.6	0.01359	70
11	160	2925	89.4	89.7	88.2	0.88	19.6	7.0	36	2.4	3.0	0.0415	105
15	160	2930	90.3	90.7	90.0	0.90	25.9	7.0	49	2.4	3.0	0.0544	120
18.5	160	2934	90.9	91.2	90.4	0.90	31.7	7.0	60	2.6	3.1	0.0581	131
22	180	2936	91.3	91.7	91.0	0.91	37.3	7.0	72	3.0	3.5	0.0679	152
30	200	2940	92.0	92.4	91.5	0.90	50.7	7.0	97	2.5	3.2	0.1077	198
37	200	2950	92.5	92.8	91.7	0.89	62.9	7.0	120	3.0	3.8	0.1332	232
45	225	2956	92.9	92.6	92.0	0.90	75.7	7.0	145	2.4	3.2	0.2443	295
55	250	2960	93.2	93.8	92.8	0.90	91.7	7.0	177	2.6	3.0	0.3160	344
75	280	2970	93.8	93.8	92.8	0.92	121	7.0	241	2.3	2.7	1.025	690
90	280	2970	94.1	94.1	93.1	0.92	145	7.0	289	2.3	2.5	1.2	685

### 1500 RPM

Output kW	Frame Size	Speed RPM	Efficiency			Power factor cosφ	Current		Torque			Moment of inertia J=1/4GD <sup>2</sup> (Kgm <sup>2</sup> )	Weigh kg
			Full load 100%	3/4 load 75%	1/2 load 50%		I <sub>n</sub> A	I <sub>s</sub> / I <sub>n</sub>	T <sub>m</sub> / Nm	T <sub>1</sub> / T <sub>n</sub>	T <sub>s</sub> / T <sub>n</sub>		
0.37	71	1380	70.1	70.1	68.7	0.83	0.9	4	2.6	1.6	2.1	0.00088	11
0.55	80	1415	75.1	75.1	71.4	0.73	1.4	5	3.7	2	2.8	0.00144	15
0.75	80	1430	79.6	79.6	76.2	0.73	1.8	6	5	2.7	3.2	0.00205	17
1.1	90	1435	81.4	81.4	80.9	0.8	2.4	6	7.3	2.7	3.4	0.0044	25
1.5	90	1430	82.8	82.8	81	0.83	3	6	10	2.5	3	0.00538	27
2.2	100	1450	84.3	84.3	82.6	0.78	4.7	7	14.5	2.9	3.6	0.00948	36
3.7	112	1440	86.3	86.3	85.9	0.81	7.4	7	24.5	2.5	2.9	0.0125	44
5.5	132	1460	87.7	87.7	86.8	0.8	10.9	7	36	1.8	2.4	0.03282	70
7.5	132	1450	88.7	88.7	86	0.81	14.5	7	49.4	1.6	2.4	0.03659	73
9.3	160	1460	89.3	89.8	88	0.84	17.4	7	61	2.3	2.9	0.0738	107
11	160	1463	89.8	90.4	89.4	0.85	20.2	7	72	2.3	2.9	0.084	115
15	160	1463	90.6	91.2	90.2	0.84	27.6	7	98	2.5	3.1	0.1025	134
18.5	180	1464	91.2	91.8	90.9	0.84	33.8	7	121	2.9	3.5	0.1217	155
22	180	1465	91.6	92.1	91.2	0.83	40.5	7	143	2.5	3.2	0.1396	171
30	200	1474	92.3	92.5	91.8	0.84	54.1	7	194	2.7	3.5	0.2572	229
37	225	1478	92.7	93.1	92.2	0.85	65.7	6.5	239	2.3	2.7	0.3605	267
45	225	1478	93.1	93.5	92.6	0.84	80.5	7	291	2.4	2.9	0.4314	304
55	250	1478	93.5	93.7	92.9	0.85	96.8	7	355	2.7	3	0.5331	342
75	280	1478	94	94	93	0.87	128	7	485	2.4	2.7	1.11	670
90	280	1479	94.2	94.2	93.2	0.85	156	7	581	2.6	2.8	1.425	730

# IE2

## TECHNICAL DETAILS

1000 RPM

General performance cast iron motors  
Technical data for totally enclosed squirrel  
cage three phase motors

Output kW	Frame Size	Speed RPM	Efficiency			Power factor cosφ	Current		Torque			Moment of inertia J=1/4GD <sup>2</sup> (Kgm <sup>2</sup> )	Weigh kg
			Full load 100%	3/4 load 75%	1/2 load 50%		I <sub>n</sub> , A	I <sub>s</sub> / I <sub>n</sub>	T <sub>n</sub> / Nm	T <sub>l</sub> / T <sub>n</sub>	T <sub>s</sub> / T <sub>n</sub>		
0.37	80	915	69	69	64.4	0.69	1.1	6	3.9	1.8	2.2	0.00187	15
0.55	80	920	72.9	72.9	70.6	0.71	1.5	6	5.7	1.8	2.2	0.00239	17
0.75	90	960	75.9	75.9	69.7	0.6	2.3	6	7.5	2.3	3.1	0.00444	25
1.1	90	930	78.1	78.1	75.4	0.66	3	6	11.3	1.9	2.3	0.0054	28
1.5	100	950	79.8	79.8	76.8	0.69	3.8	6	15	2.2	2.7	0.00873	37
2.2	112	950	81.8	81.8	79.3	0.69	5.4	7	22.1	1.7	2.3	0.0125	44
3.7	132	970	84.3	84.3	82.4	0.7	8.8	7	36.4	1.5	2.2	0.03336	69
5.5	132	965	86	86	85	0.71	12.5	7	54.4	2.5	2.8	0.0487	86
7.5	160	967	87.2	88	86.8	0.79	15.3	6.5	74	1.9	2.6	0.0890	122
9.3	160	968	88	88.6	87.8	0.79	18.9	6.5	92	2.1	2.8	0.1190	141
11	160	970	88.7	89.2	88.5	0.78	22.3	7	108	2.3	3	0.1293	147
15	180	972	89.7	90.1	89.4	0.76	30.9	7	147	2.3	3.2	0.1522	173
18.5	200	972	90.4	90.8	90	0.79	36.5	6	182	1.7	2.5	0.1980	190
22	200	973	90.9	91.2	90.6	0.79	43.1	6	216	1.7	2.5	0.2384	212
30	225	985	91.7	92	91.2	0.83	55.2	6.5	291	2.3	2.8	0.5687	284
37	250	985	92.2	92.4	91.9	0.82	68.5	6	359	2	2.6	0.8042	337
45	280	988	92.7	92.7	90.7	0.84	80	7	435	2.2	2.4	1.8	590
55	280	988	93.1	93.1	91.1	0.84	98	7	532	2.2	2.4	2.025	600
75	315	989	93.7	93.7	91.7	0.85	131	7	724	2.4	2.7	3.887	932
90	315	990	94	94	92	0.85	157	7	868	2.4	2.8	4.8	1005

Efficiency values are given according to IEC 60034-2-1:2007.

Please note that the values are not comparable without knowing the testing method.

New Bharat has calculated the efficiency values according to indirect method, stray load losses (additional losses) determined from measuring. IE-class concerns motors from 0.37 kW to 90 kW

I<sub>s</sub> / I<sub>n</sub> = Starting current  
T<sub>l</sub> / T<sub>n</sub> = Locked rotor torque  
T<sub>s</sub> / T<sub>n</sub> = Breakdown torque

# IE3

## TECHNICAL DETAILS

3000 RPM

General performance IE3 efficiency cast iron motors  
Technical data for totally enclosed squirrel  
cage three phase motors

Output kW	Frame Size	Speed RPM	Efficiency			Power factor cosφ	Current		Torque			Moment of inertia J=1/4GD <sup>2</sup> (Kgm <sup>2</sup> )	Weigh kg
			Full load 100%	3/4 load 75%	1/2 load 50%		I <sub>n</sub> , A	I <sub>s</sub> / I <sub>n</sub>	T <sub>n</sub> / Nm	T <sub>l</sub> / T <sub>n</sub>	T <sub>s</sub> / T <sub>n</sub>		
0.37	71	2790	75.5	75.4	72.7	0.81	0.84	4.6	1.3	2.2	2.5	0.00033	9
0.55	71	2785	78.1	78.4	76.4	0.8	1.22	4.6	1.9	2.3	2.6	0.00041	10
0.75	80	2875	80.7	80	76.7	0.8	1.62	6.2	2.5	3	3.6	0.0008	14
1.1	80	2865	82.7	83.4	81.9	0.84	2.2	6.7	3.7	3	3.6	0.00119	17
1.5	90	2885	84.2	84.6	83	0.86	2.9	6.1	5	2.9	3.3	0.00224	21
2.2	90	2890	85.9	86.7	85.8	0.88	4	7	7.3	3	3.5	0.00304	25
3.7	100	2900	87.8	88.1	86.8	0.88	6.7	7.5	12.1	3.5	3.9	0.00756	42
5.5	132	2900	89.2	89.6	88.9	0.86	10	6.6	18	2.3	3.4	0.163	69
7.5	132	2905	90.1	90.5	89.7	0.86	13.5	6.3	24.6	2.5	3.5	0.0182	74
9.3	160	2940	90.7	90.8	89.7	0.89	16.2	7.7	30.1	2.8	3.8	0.053	115
11	160	2942	91.2	91.5	90.8	0.9	18.7	7.7	35.7	2.8	3.6	0.057	118
15	160	2944	91.9	92.1	91.3	0.88	26	7.7	48.6	3	4	0.063	126
18.5	160	2995	92.4	92.9	92.5	0.9	31.2	7.7	59.8	3	3.9	0.076	144
22	180	2955	92.7	93.2	92.7	0.9	37.1	7.7	71	3	3.7	0.11	181
30	200	2957	93.3	93.6	93.2	0.89	51	7	96.8	2.9	3.3	0.182	230
37	200	2958	93.7	94.1	93.6	0.9	61.8	7	119.3	2.9	3.4	0.222	257
45	225	2966	94	94.1	93.3	0.87	77.3	7	144.7	2.9	3.4	0.296	287
55	250	2968	94.3	94.3	93.5	0.89	92.5	6.7	176.9	2.8	3.1	0.426	344
75	280	2970	94.7	94.7	93.7	0.9	122	7.7	241	2.5	2.8	1.025	700
90	280	2970	95	95	94	0.9	146	7.7	289	2	2.6	1.214	740

# IE3

## TECHNICAL DETAILS

General performance ie3 efficiency cast iron motors  
 Technical data for totally enclosed squirrel  
 cage three phase motors

### 1500 RPM

Output kW	Frame Size	Speed RPM	Efficiency			Power factor cosφ	Current		Torque			Moment of inertia J=1/4GD <sup>2</sup> (Kgm <sup>2</sup> )	Weigh kg
			Full load 100%	3/4 load 75%	1/2 load 50%		I <sub>n</sub> , A	I <sub>s</sub> / I <sub>n</sub>	T <sub>n</sub> / Nm	T <sub>l</sub> / T <sub>n</sub>	T <sub>b</sub> / T <sub>n</sub>		
0.37	71	1435	73	69.8	62.7	0.65	1.08	4.6	2.5	2.7	3	0.00082	10
0.55	80	1430	78	77.4	73.8	0.72	1.36	5.3	3.7	2.7	2.8	0.00195	15
0.75	80	1445	82.5	81.1	77.1	0.7	1.81	4.5	5	3.5	3.9	0.00309	20
1.1	90	1435	84.1	83.7	81	0.73	2.5	5.5	7.4	3.3	3.7	0.00397	22
1.5	90	1431	85.3	85.2	82.9	0.75	3.3	6	10.1	3.5	3.9	0.00486	25
2.2	100	1450	86.7	86.9	85.1	0.76	4.6	6.8	14.5	3.1	3.7	0.00919	34
3.7	112	1455	88.4	88.5	87	0.77	7.6	7	24.4	3.5	3.9	0.0154	50
5.5	132	1464	89.6	90.6	89.2	0.8	10.7	6.3	36.1	2.2	3	0.0351	72
7.5	132	1467	90.4	90.9	90.3	0.8	14.4	3.1	49.2	2.2	3.5	0.0411	84
9.3	160	1475	91	90.9	89.5	0.79	18.2	7.5	60	3	4	0.105	130
11	160	1475	91.4	91.5	90.5	0.8	21.2	7.5	71	2.9	3.8	0.11	134
15	160	1475	92.1	92.2	91.3	0.8	28.8	7.5	96.9	3	3.9	0.135	159
18.5	160	1479	92.6	93	92.5	0.82	34	7.5	119.2	2.8	3.3	0.219	192
22	180	1479	93	93.5	93	0.82	40.7	7.5	141.8	3	3.5	0.243	205
30	200	1482	93.6	93.8	93.2	0.83	53.4	7.5	192.9	3	3.3	0.385	259
37	225	1482	93.9	94.2	93.8	0.83	68.1	6.8	238.3	2.9	3.2	0.427	274
45	225	1482	94.2	94.6	94.3	0.83	81.6	6.8	290	2.7	3.1	0.525	307
55	250	1482	94.6	94.7	94.1	0.84	98.5	7	354.2	3	3.4	0.694	358
75	280	1478	95	95	94	0.85	129	7.7	485	2.6	2.8	1.495	690
90	280	1479	95.2	95.2	94.2	0.85	155	7.7	581	2.6	2.8	1.725	750

### 1000 RPM

Output kW	Frame Size	Speed RPM	Efficiency			Power factor cosφ	Current		Torque			Moment of inertia J=1/4GD <sup>2</sup> (Kgm <sup>2</sup> )	Weigh kg
			Full load 100%	3/4 load 75%	1/2 load 50%		I <sub>n</sub> , A	I <sub>s</sub> / I <sub>n</sub>	T <sub>n</sub> / Nm	T <sub>l</sub> / T <sub>n</sub>	T <sub>b</sub> / T <sub>n</sub>		
0.37	80	931	71.9	70.6	65.6	0.65	1.1	3.9	3.8	2.5	2.8	0.0022	15
0.55	80	941	75.9	74.9	70.4	0.64	1.58	4.4	5.6	3.1	3.3	0.00349	19
0.75	90	948	78.9	77.5	73.2	0.62	2.1	3.9	7.6	2.5	3	0.00487	25
1.1	90	951	81	79.7	75.4	0.62	3	3.1	11.2	3.3	3.6	0.00676	30
1.5	100	954	82.5	82.6	80.2	0.67	3.8	4.1	15.2	2.2	2.4	0.00994	37
2.2	112	957	84.3	84.4	82.5	0.67	5.4	4.6	22.2	2.1	2.7	0.0139	47
3.7	132	967	86.5	87	86	0.69	8.6	4.7	37	1.6	2.7	0.0354	72
5.5	132	970	88	88.3	87.3	0.69	12.6	4.7	54.7	1.6	2.8	0.0533	97
7.5	160	972	89.1	90.2	90	0.75	15.7	6.5	73.3	2.1	3.1	0.089	119
9.3	160	977	89.8	90.3	89.7	0.75	20.3	6	90.7	2	3.1	0.128	153
11	160	977	90.3	91	90.7	0.74	22.9	6	107.5	1.8	2.8	0.138	160
15	160	979	91.2	91.6	91	0.77	30.3	5	146.2	1.5	2.6	0.212	190
18.5	200	988	91.7	91.8	90.9	0.81	34.5	7	178.6	2.4	3.1	0.196	238
22	200	989	92.2	92.2	91.1	0.81	41.6	7.5	212.2	2.6	3.6	0.585	263
30	225	989	92.9	93	92	0.78	59.2	7	290.3	2.6	3.4	0.724	285
37	250	990	93.3	93.7	93.4	0.82	68	6	356.6	2.3	2.5	1.3	379
45	280	988	93.7	93.7	91.7	0.84	80	7.7	435	2.3	2.6	2.3	655
55	280	988	94.1	94.1	92.1	0.84	97	7.7	532	2.5	2.6	2.45	680
75	315	989	94.6	94.6	92.6	0.84	131	7.7	724	2.5	2.6	4.725	925
90	315	990	94.9	94.9	92.9	0.84	157	7.7	868	2.5	2.8	5.425	1010

Efficiency values are given according to IEC 60034-2-1;2007.  
 Please note that the values are not comparable without knowing the testing method.  
 New Bharat has calculated the efficiency values according to indirect method, stray load losses (additional losses) determined from measuring. IE-class concerns motors from 0.37 kW to 90 kW

I<sub>s</sub> / I<sub>n</sub> = Starting current  
 T<sub>l</sub> / T<sub>n</sub> = Locked rotor torque  
 T<sub>b</sub> / T<sub>n</sub> = Breakdown torque

# DIMENSION

## B-3

### Construction Horizontal Foot Mounted

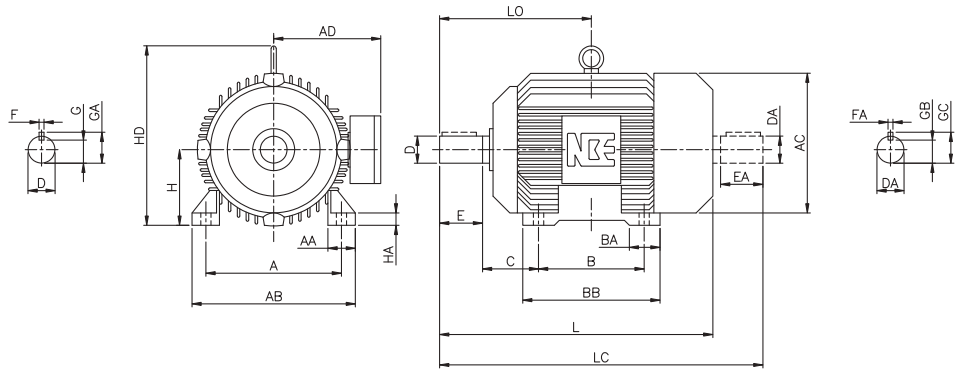

Frame Size	A	B	C	H	K	L	LC	LO	AA	AB	BB	BA	AC	HA	HD	AD	D, DA	E, EA	F, FA	GA GC	G, GB
56	90	71	36	56	6	180	204	-	25	110	91	-	110	6	-	86	9	20	3	10.2	7.2
63	100	80	37	63	7	208	212	-	31	132	110	27	116	10	-	103	11	23	4	12.5	8.5
71	112	90	52	71	7	277	276	-	31	141	113	31	139	10	-	110	16	50	5	18.5	11
80	125	100	52	80	10	288	324	-	40	163	130	32	157	13	-	120	19	40	6	21.5	15.5
90S	140	100	56	90	10	308	354	-	40	175	126	32	177	13	178	140	24	48	8	27.5	20
90L	140	125	56	90	10	332	379	-	40	175	157	32	177	13	178	140	24	51	8	27.5	20
100L	160	140	63	100	12	377	433	-	42	197	168	46	199	14	250	151	28	60	8	31.5	24
112M	190	140	70	112	12	405	456	205	48	225	180	47	225	14	274	161	28	60	8	31.5	24
132S	216	140	89	132	12	437	524	257	52	256	180	48	262	16	305	190	38	80	10	42	33
132M	216	178	89	132	12	475	562	260	52	256	218	48	262	16	305	190	38	80	10	42	33
160M	254	210	110	160	15	604	693	317	66	317	266	75	320	24	365	230	42	110	12	46	37
160L	254	254	110	60	15	652	737	346	66	315	334	95	320	24	365	235	42	110	12	46	37
180M	279	279	110	180	15	696	798	371	80	360	335	101	362	30	405	255	48	110	14	51	41
180L	279	279	110	180	15	696	798	371	80	360	335	101	362	30	405	255	48	110	14	51	41
200L	318	305	133	200	19	760	880	416	84	386	365	74	395	26	457	290	55	110	16	59	49
225S	356	286	163	225	19	865	925	436	94	428	423	129	443	32	505	322	60	142	18	59	51
225SX	356	286	149	225	19	835	985	466	90	428	371	91	435	28	518	315	60	140	18	64	53
225M	356	311	149	225	19	805	925	436	90	428	371	91	435	28	518	315	55	140	16	59	49
225MX	356	311	149	225	19	835	985	466	90	428	371	91	435	28	518	315	60	140	18	64	53
250M	406	349	168	250	24	930	1080	524	105	490	433	93	485	38	563	385	60	140	18	64	53
250MX	406	349	168	250	24	930	1080	524	105	490	433	93	485	38	563	385	65	140	18	69	58
280S	457	368	190	280	24	1030	1180	590	100	557	483	145	540	42	618	415	65	140	18	69	58
280SX	457	368	190	280	24	1030	1180	590	100	557	483	145	540	42	618	415	75	140	20	80	68
280M	457	419	190	280	24	1030	1180	590	100	557	483	145	540	42	618	415	65	140	18	69	58
280MX	457	419	190	280	24	1030	1180	590	100	557	483	145	540	42	618	415	75	140	20	80	68

in 56, 63 terminal box located at the top side of the motor  
NOTE : TOP BOX AVAILABLE

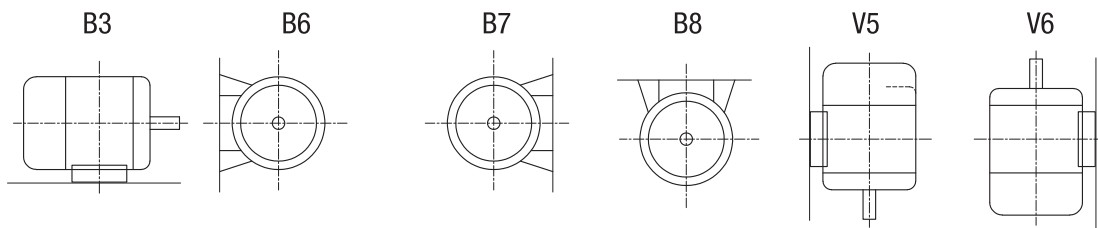

FOOT MOUNTINGS

FLANGE MOUNTINGS

FACE MOUNTINGS

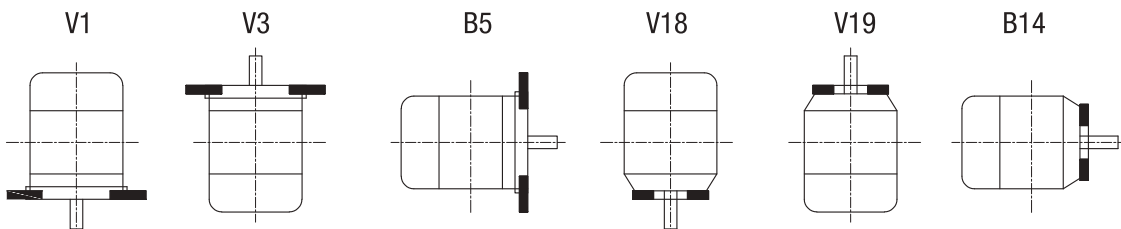

# B-5

## Construction Flange Mounted

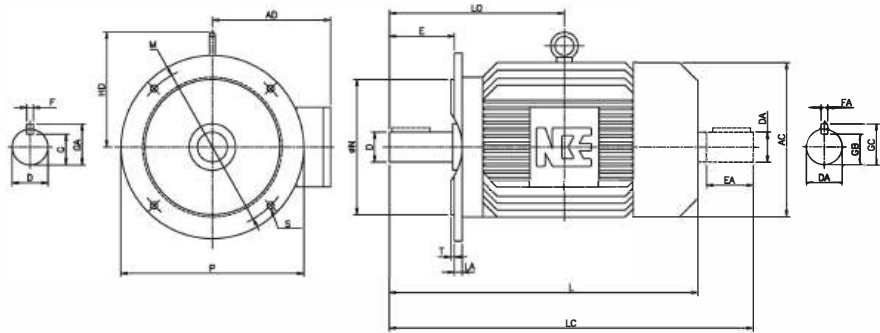

Frame Size	L	LC	LO	AC	HD	AD	D <sub>1</sub> DA	E <sub>1</sub> EA	F <sub>1</sub> FA	GA GC	G <sub>1</sub> GB	P max	M PCD	øN	S	No. of Hole	T max	LA
56	180	204	-	110	-	86	9	20	3	10.2	7.2	140	115	95	10	4	3	9
63	216	222	-	124	-	103	11	23	4	12.5	8.5	140	115	95	10	4	3	9
71	240	276	-	140	-	110	14	30	5	16	11	160	130	110	10	4	3.5	9
80	277	324	-	158	-	120	19	40	6	21.5	15.5	200	165	130	12	4	3.5	10
90S	297	354	-	180	-	140	24	50	8	27	20	200	165	130	12	4	3.5	10
90L	322	379	-	180	-	140	24	50	8	27	20	200	165	130	12	4	3.5	10
100L	366	433	-	198	-	152	28	60	8	31	24	250	215	180	15	4	4	11
112M	389	456	230	222	265	165	28	60	8	31	24	250	215	180	15	4	4	11
132S	437	524	257	262	305	190	38	80	10	41	33	300	265	230	15	4	4	12
132M	475	562	260	262	305	190	38	80	10	41	33	300	265	230	15	4	4	12
160M	576	693	354	311	365	235	42	110	12	45	37	350	300	250	19	4	5	13
160L	620	737	354	311	365	235	42	110	12	45	37	350	300	250	19	4	5	13
180M	643	760	381	336	405	255	48	110	14	52	43	350	300	250	19	4	5	13
180L	681	798	381	336	405	255	48	110	14	52	43	350	300	250	19	4	5	13
200L	760	880	416	395	457	290	55	110	16	59	49	400	350	300	19	4	5	15
225S	805	925	436	435	518	315	55	110	16	59	49	450	400	350	19	8	5	16
225SX	835	985	466	435	518	315	60	140	18	64	53	450	400	350	19	8	5	16
225M	805	925	436	435	518	315	55	110	16	59	49	450	400	350	19	8	5	16
225MX	835	985	466	435	518	315	60	140	18	64	53	450	400	350	19	8	5	16
250M	930	1080	524	485	563	385	60	140	18	64	53	550	500	450	24	8	5	18
250MX	930	1080	524	485	563	385	65	140	18	69	58	550	500	450	24	8	5	18
280S	1030	1180	590	540	618	415	65	140	18	69	58	550	500	450	24	8	5	18
280SX	1030	1180	590	540	618	415	75	140	20	80	68	550	500	450	24	8	5	18
280M	1030	1180	590	540	618	415	65	140	18	69	58	550	500	450	24	8	5	18
280MX	1030	1180	590	540	618	415	75	140	20	80	68	550	500	450	24	8	5	18

# B-14

## Construction Face Mounted

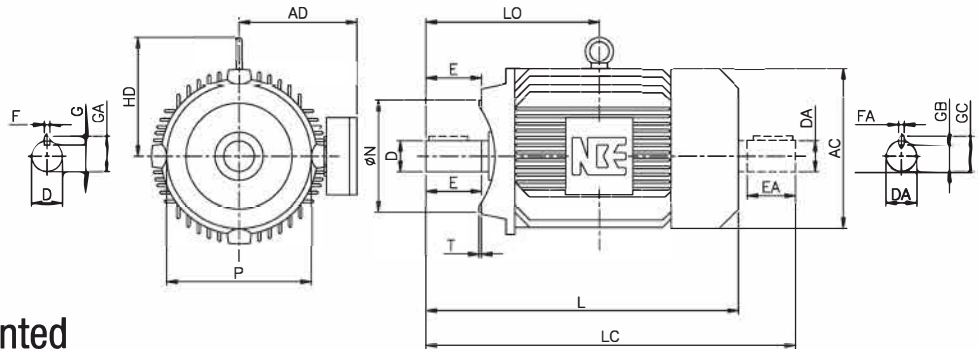

Frame Size	L	LC	LO	AC	HD	AD	D <sub>1</sub> DA	E <sub>1</sub> EA	F <sub>1</sub> FA	GA GC	G <sub>1</sub> GB	P max	M PCD	øN	S	No. of Hole	T max
56	180	204	-	110	-	86	9	20	3	10	7.2	80	65	50	M5	4	2.5
63	206	212	-	124	-	103	11	23	4	13	8.5	90	75	60	M5	4	2.5
71	240	276	-	140	-	110	14	30	5	16	11	105	85	70	M6	4	2.5
80	277	324	-	158	-	120	19	40	6	22	16	120	100	80	M6	4	3
90S	297	354	-	180	-	140	24	50	8	27	20	140	115	95	M8	4	3
90L	322	379	-	180	-	140	24	50	8	27	20	140	115	95	M8	4	3
100L	366	433	-	198	-	152	28	60	8	31	24	160	130	110	M8	4	3.5
112M	389	456	230	222	265	165	28	60	8	31	24	160	130	110	M8	4	3.5
132S	437	524	257	262	305	190	38	80	10	41	33	200	165	130	M12	4	3.5
132M	475	562	260	262	305	190	38	80	10	41	33	200	165	130	M12	4	3.5
160M	576	693	354	311	365	235	42	110	12	45	37	250	215	180	M12	4	4
160L	620	737	354	311	365	235	42	110	12	45	37	250	215	180	M12	4	4

## General & Special Purpose Industrial Motors

### Conforming to Indian Standards -

IS:325, IS:1231, IS:2223, IS:8789,  
IS:4961, IS:6362, IS:12065, IS:12075

### Supply -

415 Volts  $\pm$  10% 50 Hz  $\pm$  5% & Combined Variation  $\pm$  10%

### Mounting -

Foot Mounted (B3 - Construction)	Flange Mounted (B5 - Construction)	Face Mounted (B14 - Construction)
-------------------------------------	---------------------------------------	--------------------------------------

Protection - IP44, (IS: 4691)

Insulation -Class "F"

Ambient Temperature - 40 °C

Construction - Robust cast iron frames and end covers.  
Dynamically Balanced Rotor

### Terminal Box -

Terminal box is located on the top as a standard

### MOTORS FOR SPECIAL APPLICATION AREAS :

- Intermittent duty and Hoist/ Crane duty Motors
- Electro Magnetic Brake Motors
- Torque - rated Motors for Winders and Stalling Duty
- Textile and Loom Motors
- Cooling Tower Motors
- Machine Tool Motors.

### SPECIAL MECHANICAL FEATURES (On request)

- Motors with Double Shaft extensions
- Non -Standard Mounting Dimensions
- Non -Standard Shaft Extension
- Oil -tight shaft (OTS) on Driving End.
- Higher Degree of Protection IP54, IP55, IP 65.
- Reduced Vibration Level
- Motor for Corrosive atmosphere
- RHS or LHS Terminal Box arrangement.

### SPECIAL ELECTRICAL FEATURE (On request)

- Supply Voltage upto 550V
- Dual Voltage Motors
- Wider operating Voltages e.g.  $\pm$ 10 % or +6 % - 15 %
- Supply Frequency 60 Hz - 25 Hz
- Wider Frequency tolerance  $\pm$ 5%
- Lower Synchronous speeds, like 500 & 375 rpm.
- 2 or 3 Speeds Pole Changing Motors
- Motors with higher class of Insulation (Class F or H)
- Motors with thermal Protection



**PEC POWERTEK EQUIPMENT CO.**

API ISO 9001:2015 CERTIFIED COMPANY

MFG & Exporter of Geared Motor Gear Boxes & Electric Winches.

203, Rawal Commercial Complex, 2, Floor, L.B.S. Marg, Opp. Venna Nagar  
Mulund (west), Mumbai-400 080, India Website: [www.pecindia.com](http://www.pecindia.com) Tel: 022-40065047 / 900408588  
E-mail: [info@powertekindia.com](mailto:info@powertekindia.com) / [power@bhamini@gmail.com](mailto:power@bhamini@gmail.com) GSI NO: 3AALPHSE-122H

