

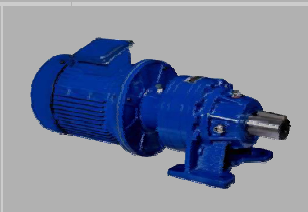

POWERTEK EQUIPMENT COMPANY
MUMBAI - INDIA

TRANSMISSION WITH PRECISION

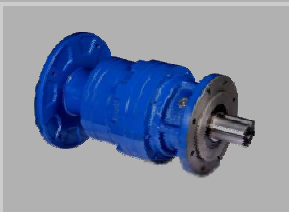

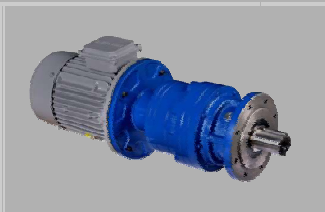

FLANGE MOUNTED PLANETARY GEARBOX

Reduction Ratio : 3.5 : 1 to 6000 : 1 Or Even more
torque Rating : 50 Nm to 250000 Nm
Input Power : 0.18 kW to 75 kW
Input Type : Hollow Input, Free Input
Output Type : Solid Shaft, Splined Shaft & Hollow



FOOT MOUNTED PLANETARY GEARBOX

Reduction Ratio : 3.5 : 1 to 6000 : 1. Or Even more
Torque Rating : 50 Nm to 250000 Nm
Input Power : 0.18 kW to 75 kW.
Input Type : Hollow Input, Free Input
Output Type : Solid Shaft, Splined Shaft & Hollow

GEARED MOTOR

Reduction Ratio : 3.5 : 1 to 3000 : 1. Or Even more
Torque Rating : 50 Nm to 150000 Nm.
Input Power : 0.18 kW to 45.0 kW
Frame Size : 63 FS to 225 FS
Output Type : Solid Shaft, Splined Shaft & Hollow Shaft



ELECTRIC WINCH

Capacity : 250 Kg to 200000 Kg
Input Power : 0.18kW to 30 kW
Rope Dia. : 6 mm to 40mm.
Line Speed : 0.1m/min to 25m/min.
Input Type : Hollow or Free

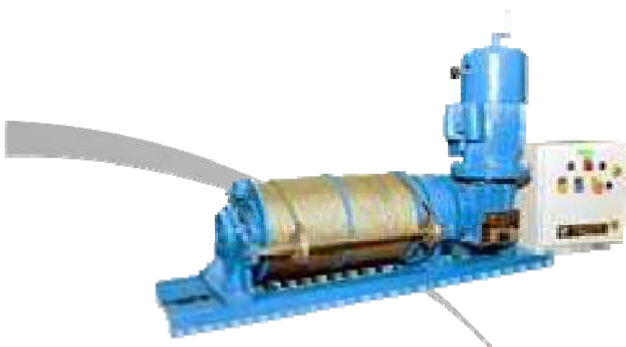

CUSTOM BUILT GEARBOX

We supply custom built gearbox, manufactured as per customer requirement & demand of application.





Powertek is headquartered at Mumbai & Factory at MIDC Satara, Maharashtra, India, engaged in the field of designing & manufacturing of planetary gearboxes as well as custom built gearboxes for various applications.

We have created a different identity with quality centric & innovative products. With the team of professionals, advanced designing software, state of the art manufacturing and testing facilities, we are strive to deliver our best services to our customers.

Our expertise in the Gear Design helped us to create Gears with proper gear teeth profile and strong gear teeth which made our gear boxes reducing noise, vibration and heat, resulting good efficiency of the gear unit.

POWERTEK EQUIPMENT CO. has got distinct business growth rate in the current transmission sector. High operating efficiency, easier mounting, space saving compactness, virtually maintenance free operation are some of the advantages of Precision gearboxes. We aim to build fruitful business relations with our customers where we become partners in fulfilling their mission. We are committed to continuous improvement & delivering best products to achieve customers trust and satisfaction.

This catalogue presents POWERTEK EQUIPMENT CO. range of planetary gearboxes.



PRODUCT SPECIFICATION

A. CONSTRUCTION

- Modular construction
- Every single stage consists of one Sun gear meshing with three to five planet gears mounted on the planet carrier
- These also mesh with the Sun gear maintaining the same direction of rotation
- The planet carrier is connected to the output shaft of the gear unit
- The design feature employed with sun gear floating among the planet gears together with accurate machining of parts, grants uniform load distribution among the planet gears.

B. SPECIFICATIONS

The range consists of multi-purpose planetary gearboxes that can be operated by hydraulic or electric motors. Basic features are;

- 40 different models
- Output torque up to 50,000nm
- Ratio from 3:5:1 to 6000:1
- Input power 0.12 Kw to 50 Kw
- Modular Design

C. VERSIONS

- Flange mounted
- Foot mounted
- Output shaft with keyway, splined, hollow shaft mounting with shrink disc

D. MATERIAL SPECIFICATION

Our expertise in gear design helped us to create gears with proper gear teeth profile & strong gear teeth. This helps to make the gearboxes with less noise, vibration & heat. This also increases efficiency of the gear unit.

Gears are made up of alloy steels like SAE 8620/20MnCr5 and are case carburized,

hardened to suitable hardness. All shafts are made from EN8/EN9/EN19 series steel and are toughened/hardened & ground.

Casings are made up of graded cast iron or cast steel necessary to withstand the load on the output shaft. Planet gears run on needle bearing while deep groove ball bearings or roller bearings are used on drive shafts.

- Mounting: Foot/ Flange

The drive can be given by pulley/sprocket or coupling with the help of solid shaft. Female shaft & flange type are also available to mount direct electric motor of flange mounted construction as per IEC standards.

The gearboxes can be offered either bevel or worm planetary combinations to have a right angled transmissions wherever orientation & application demands for.

E. INSTALLATION

For effective & proper installation, follow the instructions below.

1. Fastening

Place gearbox on a surface providing adequate rigidity. Matching surface must be machined & flat. Matching surface must be within definite geometric tolerances. This is especially true for flange mounted gearboxes with splined hollow shafts.

In application that involve high radial load at the output end, flange mounting is recommended for some gearboxes sizes as this mounting makes use of the double pilot diameters provided on these gearboxes. Make sure the gearbox is suitable for the required mounting position. Use screw of resistance class 8.8 to over secure the gearbox. With transmitted output torque greater than or equal to 70% of indicated M2 max



1.1 PRODUCT SPECIFICATION

torque and with frequent movement reversals, use screw with minimum resistance 10.9. Some gearbox sizes can be fastened using either screw or pins. If a pin is used, the length of pin seated in the frame the gearbox being installed should be at least 1.5 times pin diameter.

2. Connections

Secure the connection parts, e.g. couplings, pulleys input & output. So not tap them with hammers or similar tools. To insert these parts, use the service screws and threaded holes provide on the shaft. Be sure to clean off any grease or protectants from the shafts before fitting any connections part.

- Fitting hydraulic motors

BE careful of the O ring between motor flange and gearbox input flange when assembling. Install the hydraulic motor before filling lube oil into the gearbox.

- Connecting the hydraulic brakes

The hydraulic circuit should be such to ensure that brake is released instantly before gearbox starts and applied after gearbox has stopped. Check that, the pressure in the hydraulic line for brake release is at 0 position whenever gearbox is stopped.

3. Direction of rotation

Motors are connected to suitable electric or hydraulic circuit according to their direction of rotations. When performing these connections, bear in mind that, all gearboxes whether in-line or right angle design, have the same direction of rotation both at input & output.

4. Lubrication

Before start up, fill the gearbox with the recommended lube oil up to correct level. Level is checked through the suitable plug or

sight glass provided on each gearbox depending on designed mounting position.

5. Lubrication (Prior to start up)

All gearboxes are oil-bath lubricated. For applications, calling for gearboxes vertically positioned axis, in which oil coverage during operation would not be sufficient to ensure correct lubrication of upper bearings, suitable life lubrication system.

Before start up, fill the gearbox with the correct quantity of oil selecting the viscosity level as per table. These gearboxes are provided with oil filling level & drain plugs.

For a proper plug positioning for adequate lubrication, please always specify the required mounting position. The table lists the most common brands of lubrication and the types recommended for normal applications.

Note: For applications with special operating conditions, consult the factory with complete Information. Oil temperature must not exceed 90 deg. C.

Units are delivered without oil but with filling draining and oil level plugs correctly positioned. The oil capacities indicated on gearbox for the various types of unit are indicative only. Check the oil level plug to ensure the correct amount of oil.

Should transmitted power exceed the thermal capacity of the unit forced lubrication must provided.



TECHNICAL DATA

RECOMMENDED OIL BRANDS

BRAND	AMBIENT TEMPERAURE 5°C to 30°C	AMBIENT TEMPERAURE 30°C to 65°C	AMBIENT TEMPERAURE 40°C to 75°C
INDIAN OIL	SERVO MESH 150	SERVO MESH 220	SERVO MESH 320
HINDUSTHAN	GERVIL EP 150	GERVIL EP 220	GERVIL EP 320
BHARAT PETROLIUM	GRHP 150	GRHP 220	GRHP 320
ESSO	SPARTAN EP 150	SPARTAN EP 220	SPARTAN EP 320

Reduction Ratio (I)

Actual reduction ratio provided by our standard manufacturing for any size of gear unit, which is the ratio of Input speed to Output speed.

Generated Torque

Theoretical calculated value with related to installed power & speed or calculated by formula indicated in selection procedure step -II.

Rated Torque (Tr)

Output torque value for gear stresses corresponding to the limit value, conventionally considered as corresponding to theoretically unlimited life. The values shown in the following selection table into account both the bending strength and surface strength of the tooth flanks.

Peak Torque

It is output torque that the gear box can withstand in static or highly intermittent conditions for fraction time.

Thermal Rating (Pt) Kw

This is the continuous power transmittable by a gear unit with splash lubrication and maximum oil temperature of 90° C at ambient temp of 25° & input speed 1500 RPM.

Input Speed

The input speed taken, as basis for selection table is 1440 min either for the gearbox and for the gear motor. Maximum recommended

input speed is 1800 min-1. However for bigger size gear boxes from model 80 onwards the maximum input speed values are limited and to be verified with Precision Gear Transmissions before selection.

Efficiency

This normally is 0.96/0.97 for each stage, but reduces with an increase in speed and decrease in output torque for multistage gear boxes it has to be multiplied according to stages e.g. for 2 stage $.96*0.96=0.92$.

Service Factor

It has been introduced to take into account the characteristics and working hours per day of the driven machine. Actual Service factor for selected model is ratio of rated torque to generated torque.

Allowable Temperature

Standard gear units are suitable for oil temperature between -20°C & +90°C. For temperature condition slower than -20°C and above 90° C, special material and seals may be necessary, which are provided upon request.

Loads on Output Shafts

Loads on output shaft or input shaft applied de pending on applications are defined for an ISO L10 bearing life corresponding to $n2h = 10$ which may be checked as per procedure shown in Step No. 5 of selection.



1.3 MODEL IDENTIFICATION / ORDERING CODE

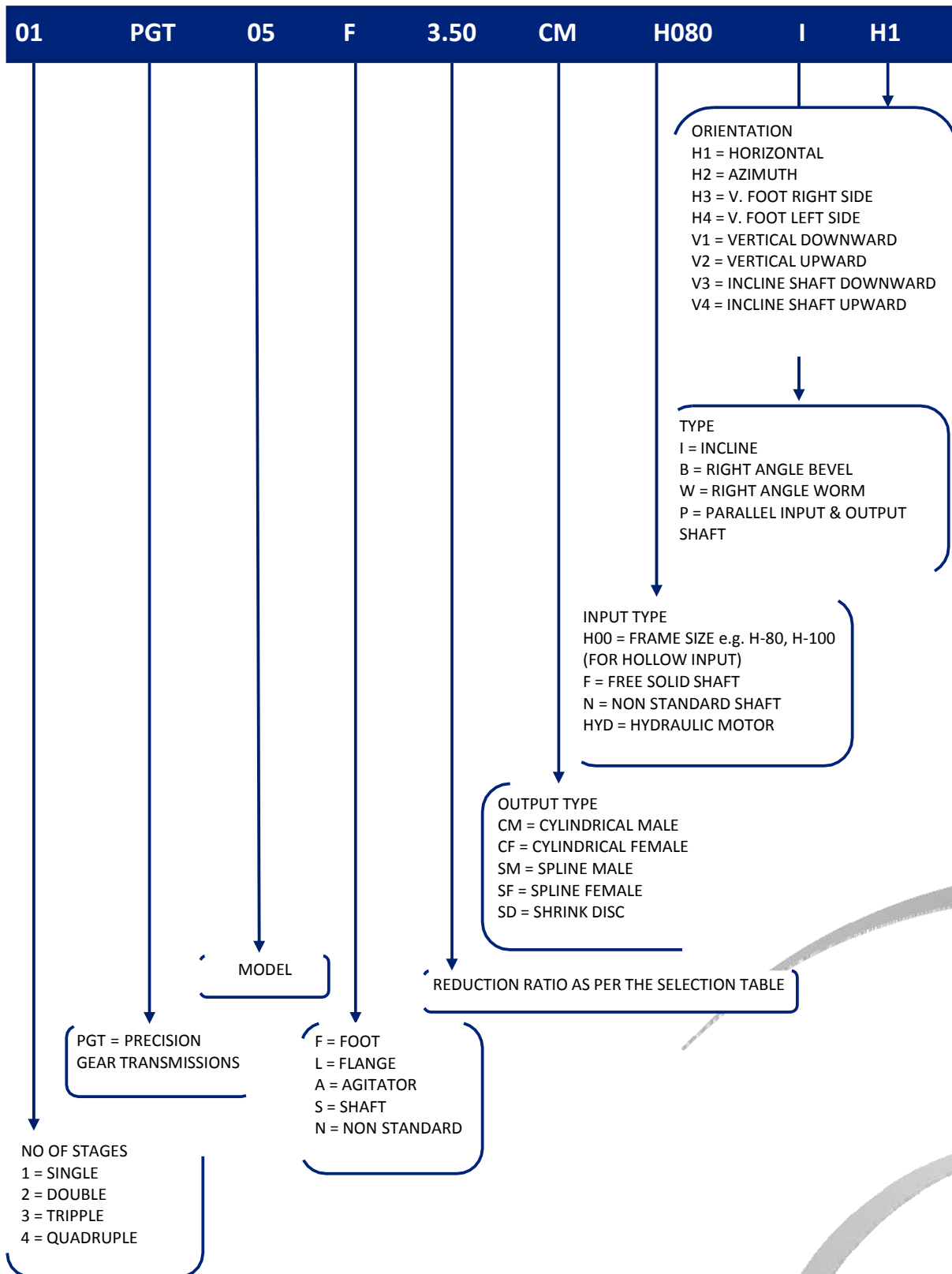



1.4 SELECTION PROCEDURE FOR PLANETARY DRIVE

To select the type of reduction gear the following instruction concerning the applications should be known.

- Torque to be transmitted (output torque)
- Input speed (RPM)
- Output speed (RPM)
- Operating condition (i.e. No of Start-ups per hour and it subject to impacts)
- Ambient temperature (OC)
- Radial load on output shaft
- Radial load on Input shaft
- Thrust load if any

After knowing the above information following steps to be followed for the selection,

STEP 1

Select the reduction ratio

$$i = \frac{\text{Input speed}}{\text{Output speed}}$$

Select nearest ration mentioned in the catalogue

STEP 2

Output torque to be transmitted. If the output torque is not known then the torque can be worked as,

$$\text{torque (Nm)} = \frac{P \times 9546}{N} \quad \text{where P is Power in Kw}$$

If the power available is in HP, convert to Kw using relation. 1Hp=0.746 Kw

This above torque either defined output torque or calculated output torque or average output torque to be multiplied by the service factor.

STEP 3

Select suitable service factor as per the application for planetary gear box



1.4 SELECTION PROCEDURE FOR PLANETARY DRIVE

STEP 4

Find out rated

torque = calculated output torque *service factor

STEP 5

Selection of mode

Select life of gearbox & rated torque of gear box from page no. 10 to 30 with respect to output Speed & life required in hours calculate $n_2 \cdot h$.

Compare the rated torque in table with torque required. For concern ratio the model selected should have more rated torque then calculated torque.

STEP 6

Verification of thermal capacity

After selection of model it is necessary to check with thermal capacity of the reducer thermal rating (Kw) Pt. It is the power a reduction gear can transmit in the continuous use at maximum operating temperature of 90C when ambient temperature is 250 C, oil viscosity is ISO VG 320 and input speed is 1440 RPM. The thermal ratings are shown in selection chart.

STEP 7

Verification of hollow frame

If selected reducer is required in hollow input configuration then it has to be verified for available frame size. Available frame sizes are shown in selection chart.



1.4 SELECTION PROCEDURE FOR PLANETARY DRIVE

STEP 8

Check for overhang load

When reducer is connected with sprocket, pulley, timing belt, gear or friction wheel there is radial load generated on shaft either high speed or low speed & this has to be checked called as overhang load capacity. Calculate the overhang load as per below mentioned formula.

$$\text{Overhang load} = \frac{19100000}{D \times n} \times P \times F_c$$

Where:

P = Power in Kw (1HP = 0.746Kw)

d = diameter of sprocket/ pulley/ gear/ Friction wheel in mm

n = Speed of shaft in RPM

F_c = Load connection factor, which is as under

CHAIN SPROCKET	GEAR	SPROCKET	V-BELT	FRICTION WHEEL
1	1.06	1.5	2.5	3.5

Compare the calculated overhang load for selected model at desired life. Compare the calculated overhang load with actual as per the load location & the distance from shaft collar if value is within limit then the selection is correct or else check the possibility of increasing the PCD of wheel & reducing the distance from collar or select next higher model.



1.5 SELECTION TABLE

MODEL	No. OF STAGES	INPUT SPEED	RATIO	OUTPUT SPEED	PEAK TORQUE, T _{max} (Nm)	NOMINAL OUTPUT TORQUE, T _n (Nm)							HOL. INPUT FRAME SIZE	THERMAL RATING kW	
						n2xh	n2xh	n2xh	n2xh	n2xh	n2xh	n2xh			
						10000	25000	50000	100000	500000	1000000	5000000			
1V02i	1	1440	3.50	411.4	96	81	77	74	70	59	53	45	63-80	2	
			3.86	373.1	122	104	98	94	89	85	75	68			58
			4.33	332.6	112	95	90	87	82	69	62	53			
			5.00	288.0	104	88	84	80	76	64	58	49			
			6.00	240.0	79	67	64	61	58	49	44	37			
2V02i	2	1440	12.25	117.6	96	81	77	74	70	59	53	45	63-80	1.00	
			13.51	106.6	96	81	77	74	70	59	53	45			
			14.90	96.6	122	104	98	94	89	75	68	58			
			16.71	86.2	122	104	98	94	89	75	68	58			
			17.50	82.3	96	81	77	74	70	59	53	45			
			18.75	76.8	112	95	90	87	82	69	62	53			
			19.30	74.6	122	104	98	94	89	75	68	58			
			21.65	66.5	112	95	90	87	82	69	62	53			
			23.16	62.2	122	104	98	94	89	75	68	58			
			25.98	55.4	112	95	90	87	82	69	62	53			
3V02i	3	1440	42.88	33.6	96	81	77	74	70	59	53	45	63-71	0.75	
			52.15	27.6	96	81	77	74	70	59	53	45			
			58.50	24.6	96	81	77	74	70	59	53	45			
			61.25	23.5	96	81	77	74	70	59	53	45			
			64.50	22.3	122	104	98	94	89	75	68	58			
			67.55	21.3	96	81	77	74	70	59	53	45			
			72.40	19.9	122	104	98	94	89	75	68	58			
			74.50	19.3	122	104	98	94	89	75	68	58			
			89.40	16.1	122	104	98	94	89	75	68	58			
			96.50	14.9	122	104	98	94	89	75	68	58			
			100.28	14.4	122	104	98	94	89	75	68	58			
			108.25	13.3	112	95	90	87	82	69	62	53			
			115.80	12.4	122	104	98	94	89	75	68	58			
			129.90	11.1	112	95	90	87	82	69	62	53			
155.88	9.2	112	95	90	87	82	69	62	53						
4V02i	4	1440	165.50	8.7	96	81	77	74	70	59	53	45	63-71	0.5	
			182.52	7.9	96	81	77	74	70	59	53	45			
			201.29	7.2	96	81	77	74	70	59	53	45			
			222.00	6.5	122	104	98	94	89	75	68	58			
			253.30	5.7	96	81	77	74	70	59	53	45			
			287.56	5.0	122	104	98	94	89	75	68	58			
			328.11	4.4	96	81	77	74	70	59	53	45			
			351.52	4.1	112	95	90	87	82	69	62	53			
			387.10	3.7	122	104	98	94	89	75	68	58			
			405.91	3.5	112	95	90	87	82	69	62	53			
			434.20	3.3	122	104	98	94	89	75	68	58			
			468.72	3.1	112	95	90	87	82	69	62	53			
			482.50	3.0	122	104	98	94	89	75	68	58			
			525.00	2.7	96	81	77	74	70	59	53	45			
			579.00	2.5	122	104	98	94	89	75	68	58			
			630.00	2.3	96	81	77	74	70	59	53	45			
			674.96	2.1	122	104	98	94	89	75	68	58			
			756.00	1.9	96	81	77	74	70	59	53	45			
			779.40	1.8	112	95	90	87	82	69	62	53			
			935.28	1.5	112	95	90	87	82	69	62	53			
1080.00	1.3	104	88	84	80	76	64	58	49						



1.5 SELECTION TABLE

MODEL	No. OF STAGES	INPUT SPEED	RATIO	OUTPUT SPEED	PEAK TORQUE, Tmax(Nm)	NOMINAL OUTPUT TORQUE, Tn (Nm)							HOL. INPUT FRAME SIZE	THERMAL RATING kW
						n2xh	n2xh	n2xh	n2xh	n2xh	n2xh	n2xh		
						10000	25000	50000	100000	500000	1000000	5000000		
1V22	1	1440	3.50	411.4	191	162	154	148	139	118	107	91	63-90	3.0
			3.86	373.1	236	200	190	183	172	146	131	112		
			4.33	332.6	223	189	180	172	162	138	124	105		
			5.00	288.0	203	172	164	157	148	125	113	96		
			6.00	240.0	152	129	122	117	110	94	84	72		
2V22	2	1440	12.25	117.6	191	162	154	148	139	118	107	91	63-80	2.0
			13.51	106.6	191	162	154	148	139	118	107	91		
			14.90	96.6	236	200	190	183	172	146	131	112		
			16.71	86.2	236	200	190	183	172	146	131	112		
			17.50	82.3	191	162	154	148	139	118	107	91		
			18.75	76.8	223	189	180	172	162	138	124	105		
			19.30	74.6	236	200	190	183	172	146	131	112		
			21.65	66.5	223	189	180	172	162	138	124	105		
			23.16	62.2	236	200	190	183	172	146	131	112		
25.98	55.4	223	189	180	172	162	138	124	105					
3V22	3	1440	42.88	33.6	191	162	154	148	139	118	107	91	63-71	1.0
			52.15	27.6	191	162	154	148	139	118	107	91		
			58.50	24.6	191	162	154	148	139	118	107	91		
			61.25	23.5	191	162	154	148	139	118	107	91		
			64.50	22.3	236	200	190	183	172	146	131	112		
			67.55	21.3	191	162	154	148	139	118	107	91		
			72.40	19.9	236	200	190	183	172	146	131	112		
			74.50	19.3	236	200	190	183	172	146	131	112		
			89.40	16.1	236	200	190	183	172	146	131	112		
			96.50	14.9	236	200	190	183	172	146	131	112		
			100.28	14.4	236	200	190	183	172	146	131	112		
			108.25	13.3	223	189	180	172	162	138	124	105		
			115.80	12.4	236	200	190	183	172	146	131	112		
			129.90	11.1	223	189	180	172	162	138	124	105		
155.88	9.2	223	189	180	172	162	138	124	105					
4V22	4	1440	165.50	8.7	191	162	154	148	139	118	107	91	63-71	0.75
			182.52	7.9	191	162	154	148	139	118	107	91		
			201.29	7.2	191	162	154	148	139	118	107	91		
			222.00	6.5	236	200	190	183	172	146	131	112		
			253.30	5.7	191	162	154	148	139	118	107	91		
			287.56	5.0	236	200	190	183	172	146	131	112		
			328.11	4.4	191	162	154	148	139	118	107	91		
			351.52	4.1	223	189	180	172	162	138	124	105		
			387.10	3.7	236	200	190	183	172	146	131	112		
			405.91	3.5	223	189	180	172	162	138	124	105		
			434.20	3.3	236	200	190	183	172	146	131	112		
			468.72	3.1	223	189	180	172	162	138	124	105		
			482.50	3.0	236	200	190	183	172	146	131	112		
			525.00	2.7	191	162	154	148	139	118	107	91		
			579.00	2.5	236	200	190	183	172	146	131	112		
			630.00	2.3	191	162	154	148	139	118	107	91		
			674.96	2.1	236	200	190	183	172	146	131	112		
			756.00	1.9	191	162	154	148	139	118	107	91		
			779.40	1.8	223	189	180	172	162	138	124	105		
			935.28	1.5	223	189	180	172	162	138	124	105		
1080.00	1.3	203	172	164	157	148	125	113	96					



1.5 SELECTION TABLE

MODEL	No. OF STAGES	INPUT SPEED	RATIO	OUTPUT SPEED	PEAK TORQUE, Tmax(Nm)	NOMINAL OUTPUT TORQUE, Tn (Nm)							HOL. INPUT FRAME SIZE	THERMAL RATING kW
						n2xh	n2xh	n2xh	n2xh	n2xh	n2xh	n2xh		
						10000	25000	50000	100000	500000	1000000	5000000		
1V03	1	1440	3.63	396.7	507	430	408	392	368	313	282	240	63-100	5.0
			4.00	360.0	470	399	379	364	342	291	262	222		
			4.50	320.0	467	396	376	361	340	289	260	221		
			5.20	276.9	396	336	319	306	288	245	220	187		
			6.25	230.4	294	249	237	227	214	182	163	139		
2V03	2	1440	13.18	109.3	507	430	408	392	368	313	282	240	63-80	3.0
			14.52	99.2	507	430	408	392	368	313	282	240		
			15.72	91.6	507	430	408	392	368	313	282	240		
			17.32	83.1	470	399	379	364	342	291	262	222		
			18.00	80.0	470	399	379	364	342	291	262	222		
			20.25	71.1	467	396	376	361	340	289	260	221		
			22.50	64.0	467	396	376	361	340	289	260	221		
			23.40	61.5	467	396	376	361	340	289	260	221		
25.00	57.6	470	399	379	364	342	291	262	222					
27.00	53.3	467	396	376	361	340	289	260	221					
3V03	3	1440	47.83	30.1	507	430	408	392	368	313	282	240	63-80	2.0
			52.71	27.3	507	430	408	392	368	313	282	240		
			60.67	23.7	507	430	408	392	368	313	282	240		
			69.28	20.8	470	399	379	364	342	291	262	222		
			80.00	18.0	470	399	379	364	342	291	262	222		
			83.20	17.3	470	399	379	364	342	291	262	222		
			90.00	16.0	470	399	379	364	342	291	262	222		
			96.00	15.0	470	399	379	364	342	291	262	222		
			108.16	13.3	470	399	379	364	342	291	262	222		
			120.00	12.0	470	399	379	364	342	291	262	222		
			135.00	10.7	467	396	376	361	340	289	260	221		
			150.00	9.6	470	399	379	364	342	291	262	222		
			162.00	8.9	467	396	376	361	340	289	260	221		
			175.78	8.2	467	396	376	361	340	289	260	221		
203.13	7.1	396	336	319	306	288	245	220	187					
4V03	4	1440	196.33	7.3	507	430	408	392	368	313	282	240	63-71	1.5
			220.24	6.5	507	430	408	392	368	313	282	240		
			272.23	5.3	507	430	408	392	368	313	282	240		
			299.98	4.8	470	399	379	364	342	291	262	222		
			323.74	4.4	470	399	379	364	342	291	262	222		
			346.40	4.2	470	399	379	364	342	291	262	222		
			374.98	3.8	470	399	379	364	342	291	262	222		
			415.68	3.5	470	399	379	364	342	291	262	222		
			450.00	3.2	470	399	379	364	342	291	262	222		
			480.00	3.0	470	399	379	364	342	291	262	222		
			500.00	2.9	470	399	379	364	342	291	262	222		
			540.00	2.7	470	399	379	364	342	291	262	222		
			580.00	2.5	470	399	379	364	342	291	262	222		
			648.00	2.2	470	399	379	364	342	291	262	222		
			720.00	2.0	470	399	379	364	342	291	262	222		
			748.80	1.9	470	399	379	364	342	291	262	222		
			810.00	1.8	467	396	376	361	340	289	260	221		
			864.00	1.7	470	399	379	364	342	291	262	222		
			1012.50	1.4	467	396	376	361	340	289	260	221		
1124.20	1.3	396	336	319	306	288	245	220	187					



1.5 SELECTION TABLE

MODEL	No. OF STAGES	INPUT SPEED	RATIO	OUTPUT SPEED	PEAK TORQUE, Tmax(Nm)	NOMINAL OUTPUT TORQUE, Tn (Nm)							HOL. INPUT FRAME SIZE	THERMAL RATING kW
						n2xh	n2xh	n2xh	n2xh	n2xh	n2xh	n2xh		
						10000	25000	50000	100000	500000	1000000	5000000		
1V04	1	1440	3.63	397	952	808	767	737	693	589	530	450	80-112	7.5
			4.00	360	855	725	689	661	622	528	476	404		
			4.50	320	861	731	694	666	627	533	479	407		
			5.20	277	627	532	505	485	456	388	349	297		
			6.25	230	495	420	399	383	360	306	275	234		
2V04	2	1440	13.18	109	952	808	767	737	693	589	530	450	80-100	5.0
			14.52	99	952	808	767	737	693	589	530	450		
			15.72	92	952	808	767	737	693	589	530	450		
			17.32	83	855	725	689	661	622	528	476	404		
			18.00	80	855	725	689	661	622	528	476	404		
			20.25	71	861	731	694	666	627	533	479	407		
			22.50	64	861	731	694	666	627	533	479	407		
			23.40	62	861	731	694	666	627	533	479	407		
			25.00	58	855	725	689	661	622	528	476	404		
27.00	53	861	731	694	666	627	533	479	407					
3V04	3	1440	47.83	30	952	808	767	737	693	589	530	450	63-90	3.0
			52.71	27	952	808	767	737	693	589	530	450		
			60.67	24	952	808	767	737	693	589	530	450		
			69.28	21	855	725	689	661	622	528	476	404		
			80.00	18	855	725	689	661	622	528	476	404		
			83.20	17	855	725	689	661	622	528	476	404		
			90.00	16	855	725	689	661	622	528	476	404		
			96.00	15	855	725	689	661	622	528	476	404		
			108.16	13	855	725	689	661	622	528	476	404		
			120.00	12	855	725	689	661	622	528	476	404		
			135.00	11	861	731	694	666	627	533	479	407		
			150.00	10	855	725	689	661	622	528	476	404		
			162.00	9	861	731	694	666	627	533	479	407		
			175.78	8	861	731	694	666	627	533	479	407		
203.13	7	627	532	505	485	456	388	349	297					
4V04	4	1440	196.33	7	952	808	767	737	693	589	530	450	63-80	2.0
			220.24	7	952	808	767	737	693	589	530	450		
			272.23	5	952	808	767	737	693	589	530	450		
			299.98	5	855	725	689	661	622	528	476	404		
			323.74	4	855	725	689	661	622	528	476	404		
			346.40	4	855	725	689	661	622	528	476	404		
			374.98	4	855	725	689	661	622	528	476	404		
			415.68	3	855	725	689	661	622	528	476	404		
			450.00	3	855	725	689	661	622	528	476	404		
			480.00	3	855	725	689	661	622	528	476	404		
			500.00	3	855	725	689	661	622	528	476	404		
			540.00	3	855	725	689	661	622	528	476	404		
			580.00	2	855	725	689	661	622	528	476	404		
			648.00	2	855	725	689	661	622	528	476	404		
			720.00	2	855	725	689	661	622	528	476	404		
			748.80	2	855	725	689	661	622	528	476	404		
			810.00	2	861	731	694	666	627	533	479	407		
			864.00	2	855	725	689	661	622	528	476	404		
			1012.50	1	861	731	694	666	627	533	479	407		
			1124.20	1	627	532	505	485	456	388	349	297		



1.5 SELECTION TABLE

MODEL	No. OF STAGES	INPUT SPEED	RATIO	OUTPUT SPEED	PEAK TORQUE, Tmax(Nm)	NOMINAL OUTPUT TORQUE, Tn (Nm)							HOL. INPUT FRAME SIZE	THERMAL RATING kW
						n2xh	n2xh	n2xh	n2xh	n2xh	n2xh	n2xh		
						10000	25000	50000	100000	500000	1000000	5000000		
1V05	1	1440	3.58	402.2	1820	1544	1467	1408	1324	1125	1013	861	100-132	10.0
			3.91	368.3	1713	1453	1381	1325	1246	1059	953	810		
			4.35	331.0	1716	1456	1383	1328	1248	1061	955	812		
			4.94	291.5	1325	1124	1068	1025	964	819	737	627		
			5.79	248.7	1023	868	825	792	744	633	569	484		
			7.09	203.1	660	560	532	511	480	408	367	312		
2V05	2	1440	13.00	110.8	1820	1544	1467	1408	1324	1125	1013	861	90-112	7.50
			14.00	102.9	1820	1544	1467	1408	1324	1125	1013	861		
			15.64	92.1	1713	1453	1381	1325	1246	1059	953	810		
			17.01	84.7	1713	1453	1381	1325	1246	1059	953	810		
			18.92	76.1	1716	1456	1383	1328	1248	1061	955	812		
			20.33	70.8	1713	1453	1381	1325	1246	1059	953	810		
			22.64	63.6	1713	1453	1381	1325	1246	1059	953	810		
			24.44	58.9	1713	1453	1381	1325	1246	1059	953	810		
			27.72	51.9	1713	1453	1381	1325	1246	1059	953	810		
30.84	46.7	1716	1456	1383	1328	1248	1061	955	812					
3V05	3	1440	45.48	31.7	1820	1544	1467	1408	1324	1125	1013	861	80-100	5.00
			50.16	28.7	1820	1544	1467	1408	1324	1125	1013	861		
			55.75	25.8	1820	1544	1467	1408	1324	1125	1013	861		
			60.89	23.6	1820	1544	1467	1408	1324	1125	1013	861		
			67.72	21.3	1820	1544	1467	1408	1324	1125	1013	861		
			76.54	18.8	1820	1544	1467	1408	1324	1125	1013	861		
			79.50	18.1	1820	1544	1467	1408	1324	1125	1013	861		
			91.49	15.7	1820	1544	1467	1408	1324	1125	1013	861		
			105.73	13.6	1820	1544	1467	1408	1324	1125	1013	861		
			120.59	11.9	1713	1453	1381	1325	1246	1059	953	810		
			131.08	11.0	1713	1453	1381	1325	1246	1059	953	810		
			146.63	9.8	1713	1453	1381	1325	1246	1059	953	810		
			169.92	8.5	1716	1456	1383	1328	1248	1061	955	812		
			218.67	6.6	1716	1456	1383	1328	1248	1061	955	812		
248.32	5.8	1325	1124	1068	1025	964	819	737	627					
4V05	4	1440	205.06	7.0	1820	1544	1467	1408	1324	1125	1013	861	71-90	3.0
			223.96	6.4	1820	1544	1467	1408	1324	1125	1013	861		
			235.87	6.1	1820	1544	1467	1408	1324	1125	1013	861		
			250.81	5.7	1820	1544	1467	1408	1324	1125	1013	861		
			281.35	5.1	1820	1544	1467	1408	1324	1125	1013	861		
			309.58	4.7	1713	1453	1381	1325	1246	1059	953	810		
			338.61	4.3	1713	1453	1381	1325	1246	1059	953	810		
			372.32	3.9	1820	1544	1467	1408	1324	1125	1013	861		
			406.64	3.5	1713	1453	1381	1325	1246	1059	953	810		
			467.83	3.1	1820	1544	1467	1408	1324	1125	1013	861		
			487.97	3.0	1713	1453	1381	1325	1246	1059	953	810		
			522.29	2.8	1713	1453	1381	1325	1246	1059	953	810		
			563.04	2.6	1713	1453	1381	1325	1246	1059	953	810		
			608.32	2.4	1820	1544	1467	1408	1324	1125	1013	861		
			698.10	2.1	1820	1544	1467	1408	1324	1125	1013	861		
			754.51	1.9	1713	1453	1381	1325	1246	1059	953	810		
			884.33	1.6	1713	1453	1381	1325	1246	1059	953	810		
			983.85	1.5	1716	1456	1383	1328	1248	1061	955	812		
			1019.53	1.4	1716	1456	1383	1328	1248	1061	955	812		
			1157.81	1.2	1325	1124	1068	1025	964	819	737	627		



1.5 SELECTION TABLE

MODEL	No. OF STAGES	INPUT SPEED	RATIO	OUTPUT SPEED	PEAK TORQUE, Tmax(Nm)	NOMINAL OUTPUT TORQUE, Tn (Nm)							HOL. INPUT FRAME SIZE	THERMAL RATING kW
						n2xh	n2xh	n2xh	n2xh	n2xh	n2xh	n2xh		
						10000	25000	50000	100000	500000	1000000	5000000		
1V55	1	1440	3.72	387	2848	2416	2296	2204	2072	1761	1585	1347	112-160	12.5
			4.09	352	2595	2202	2092	2008	1888	1605	1444	1228		
			4.58	314	2305	1956	1858	1784	1677	1425	1283	1090		
			5.25	274	1724	1463	1390	1334	1254	1066	959	816		
			6.23	231	1228	1042	990	950	893	759	683	581		
			7.80	185	853	724	688	660	620	527	475	403		
2V55	2	1440	13.84	104	2848	2416	2296	2204	2072	1761	1585	1347	100-132	10.0
			16.18	89	2848	2416	2296	2204	2072	1761	1585	1347		
			18.38	78	2848	2416	2296	2204	2072	1761	1585	1347		
			23.18	62	2848	2416	2296	2204	2072	1761	1585	1347		
			26.37	55	2848	2416	2296	2204	2072	1761	1585	1347		
			29.02	50	2848	2416	2296	2204	2072	1761	1585	1347		
			32.47	44	2305	1956	1858	1784	1677	1425	1283	1090		
			35.72	40	2305	1956	1858	1784	1677	1425	1283	1090		
			37.22	39	2305	1956	3318	3185	2994	2545	2290	1947		
40.95	35	2305	1956	3318	3185	2994	2545	2290	1947					
3V55.	3	1440	56.87	25	2848	2416	2296	2204	2072	1761	1585	1347	90-112	7.5
			65.45	22	2848	2416	2296	2204	2072	1761	1585	1347		
			77.39	19	2595	2202	2092	2008	1888	1605	1444	1228		
			87.89	16	2595	2202	2092	2008	1888	1605	1444	1228		
			95.56	15	2848	2416	2296	2204	2072	1761	1585	1347		
			106.40	14	2848	2416	2296	2204	2072	1761	1585	1347		
			114.86	13	2848	2416	2296	2204	2072	1761	1585	1347		
			124.71	12	2848	2416	2296	2204	2072	1761	1585	1347		
			137.11	11	2595	2202	2092	2008	1888	1605	1444	1228		
			143.25	10	2595	2202	2092	2008	1888	1605	1444	1228		
			153.54	9	2305	1956	1858	1784	1677	1425	1283	1090		
			167.06	9	2595	2202	2092	2008	1888	1605	1444	1228		
			188.01	8	2305	1956	1858	1784	1677	1425	1283	1090		
			205.60	7	2595	2202	2092	2008	1888	1605	1444	1228		
230.23	6	2305	1956	1858	1784	1677	1425	1283	1090					
4V55i	4	1440	232.72	6	2848	2416	2296	2204	2072	1761	1585	1347	80-100	5.0
			261.81	6	2848	2416	2296	2204	2072	1761	1585	1347		
			327.69	4	2848	2416	2296	2204	2072	1761	1585	1347		
			378.66	4	2848	2416	2296	2204	2072	1761	1585	1347		
			436.91	3	2848	2416	2296	2204	2072	1761	1585	1347		
			481.08	3	2595	2202	2092	2008	1888	1605	1444	1228		
			525.92	3	2848	2416	2296	2204	2072	1761	1585	1347		
			578.22	2	2595	2202	2092	2008	1888	1605	1444	1228		
			632.11	2	2848	2416	2296	2204	2072	1761	1585	1347		
			664.63	2	2595	2202	2092	2008	1888	1605	1444	1228		
			694.98	2	2595	2202	2092	2008	1888	1605	1444	1228		
			717.84	2	2848	2416	2296	2204	2072	1761	1585	1347		
			743.06	2	2305	1956	1858	1784	1677	1425	1283	1090		
			789.24	2	2595	2202	2092	2008	1888	1605	1444	1228		
			841.36	2	2848	2416	2296	2204	2072	1761	1585	1347		
			883.80	2	2305	1956	1858	1784	1677	1425	1283	1090		
			925.04	2	2595	2202	2092	2008	1888	1605	1444	1228		
			958.59	2	2595	2202	2092	2008	1888	1605	1444	1228		
1035.87	1	2305	1956	1858	1784	1677	1425	1283	1090					
1073.44	1	2305	1956	1858	1784	1677	1425	1283	1090					



1.5 SELECTION TABLE

MODEL	No. OF STAGES	INPUT SPEED	RATIO	OUTPUT SPEED	PEAK TORQUE, Tmax(Nm)	NOMINAL OUTPUT TORQUE, Tn (Nm)							HOL. INPUT FRAME SIZE	THERMAL RATING kW
						n2xh	n2xh	n2xh	n2xh	n2xh	n2xh	n2xh		
						10000	25000	50000	100000	500000	1000000	5000000		
1V06	1	1440	3.58	402.2	3993	3388	3219	3090	2904	2469	2222	1889	132-180	15.0
			3.91	368.3	4196	3560	3382	3247	3052	2594	2335	1985		
			4.35	331.0	3665	3109	2954	2836	2666	2266	2039	1733		
			4.94	291.5	2866	2432	2310	2218	2085	1772	1595	1356		
			5.79	248.7	2185	1854	1761	1690	1589	1351	1216	1033		
			7.09	203.1	1280	1086	1032	991	931	792	712	606		
2V06	2	1440	13.00	110.8	3993	3388	3219	3090	2904	2469	2222	1889	100-132	12.5
			14.00	102.9	3993	3388	3219	3090	2904	2469	2222	1889		
			15.64	92.1	4196	3560	3382	3247	3052	2594	2335	1985		
			17.01	84.7	4196	3560	3382	3247	3052	2594	2335	1985		
			18.92	76.1	3665	3109	2954	2836	2666	2266	2039	1733		
			20.33	70.8	4196	3560	3382	3247	3052	2594	2335	1985		
			22.64	63.6	4196	3560	3382	3247	3052	2594	2335	1985		
			24.44	58.9	4196	3560	3382	3247	3052	2594	2335	1985		
			27.72	51.9	4196	3560	3382	3247	3052	2594	2335	1985		
3V06	3	1440	45.48	31.7	3993	3388	3219	3090	2904	2469	2222	1889	90-112	7.5
			50.16	28.7	3993	3388	3219	3090	2904	2469	2222	1889		
			55.75	25.8	3993	3388	3219	3090	2904	2469	2222	1889		
			60.89	23.6	3993	3388	3219	3090	2904	2469	2222	1889		
			67.72	21.3	3993	3388	3219	3090	2904	2469	2222	1889		
			76.54	18.8	3993	3388	3219	3090	2904	2469	2222	1889		
			79.50	18.1	3993	3388	3219	3090	2904	2469	2222	1889		
			91.49	15.7	3993	3388	3219	3090	2904	2469	2222	1889		
			105.73	13.6	3993	3388	3219	3090	2904	2469	2222	1889		
			120.59	11.9	4196	3560	3382	3247	3052	2594	2335	1985		
			131.08	11.0	4196	3560	3382	3247	3052	2594	2335	1985		
			146.63	9.8	4196	3560	3382	3247	3052	2594	2335	1985		
			169.92	8.5	3665	3109	2954	2836	2666	2266	2039	1733		
			218.67	6.6	3665	3109	2954	2836	2666	2266	2039	1733		
248.32	5.8	2866	2432	2310	2218	2085	1772	1595	1356					
4V06	4	1440	205.06	7.0	3993	3388	3219	3090	2904	2469	2222	1889	80-100	5.0
			223.96	6.4	3993	3388	3219	3090	2904	2469	2222	1889		
			235.87	6.1	3993	3388	3219	3090	2904	2469	2222	1889		
			250.81	5.7	3993	3388	3219	3090	2904	2469	2222	1889		
			281.35	5.1	3993	3388	3219	3090	2904	2469	2222	1889		
			309.58	4.7	4196	3560	3382	3247	3052	2594	2335	1985		
			338.61	4.3	4196	3560	3382	3247	3052	2594	2335	1985		
			372.32	3.9	3993	3388	3219	3090	2904	2469	2222	1889		
			406.64	3.5	4196	3560	3382	3247	3052	2594	2335	1985		
			467.83	3.1	3993	3388	3219	3090	2904	2469	2222	1889		
			487.97	3.0	4196	3560	3382	3247	3052	2594	2335	1985		
			522.29	2.8	4196	3560	3382	3247	3052	2594	2335	1985		
			563.04	2.6	4196	3560	3382	3247	3052	2594	2335	1985		
			608.32	2.4	3993	3388	3219	3090	2904	2469	2222	1889		
			698.10	2.1	3993	3388	3219	3090	2904	2469	2222	1889		
			754.51	1.9	4196	3560	3382	3247	3052	2594	2335	1985		
			884.33	1.6	4196	3560	3382	3247	3052	2594	2335	1985		
			983.85	1.5	3665	3109	2954	2836	2666	2266	2039	1733		
			1019.53	1.4	3665	3109	2954	2836	2666	2266	2039	1733		
1157.81	1.2	2866	2432	2310	2218	2085	1772	1595	1356					



1.5 SELECTION TABLE

MODEL	No. OF STAGES	INPUT SPEED	RATIO	OUTPUT SPEED	PEAK TORQUE, Tmax(Nm)	NOMINAL OUTPUT TORQUE, Tn (Nm)							HOL. INPUT FRAME SIZE	THERMAL RATING kW
						n2xh	n2xh	n2xh	n2xh	n2xh	n2xh	n2xh		
						10000	25000	50000	100000	500000	1000000	5000000		
1V07	1	1440	3.72	387	5699	4836	4594	4410	4145	3524	3171	2696	132-180	20.0
			4.09	352	5372	4558	4330	4157	3908	3322	2989	2541		
			4.58	314	4610	3912	3716	3567	3353	2850	2565	2181		
			5.25	274	3676	3119	2963	2845	2674	2273	2046	1739		
			6.23	231	2591	2198	2088	2005	1884	1602	1441	1225		
			7.80	185	1536	1303	1238	1189	1117	950	855	727		
2V07	2	1440	13.84	104	5699	4836	4594	4410	4145	3524	3171	2696	112-160	12.5
			16.18	89	5699	4836	4594	4410	4145	3524	3171	2696		
			18.38	78	5699	4836	4594	4410	4145	3524	3171	2696		
			23.18	62	5699	4836	4594	4410	4145	3524	3171	2696		
			26.37	55	5699	4836	4594	4410	4145	3524	3171	2696		
			29.02	50	5699	4836	4594	4410	4145	3524	3171	2696		
			32.47	44	4610	3912	3716	3567	3353	2850	2565	2181		
			35.72	40	4610	3912	3716	3567	3353	2850	2565	2181		
			37.22	39	4610	3912	3318	3185	2994	2545	2290	1947		
40.95	35	4610	3912	3318	3185	2994	2545	2290	1947					
3V07	3	1440	56.87	25	5699	4836	4594	4410	4145	3524	3171	2696	90-132	12.5
			65.45	22	5699	4836	4594	4410	4145	3524	3171	2696		
			77.39	19	5372	4558	4330	4157	3908	3322	2989	2541		
			87.89	16	5372	4558	4330	4157	3908	3322	2989	2541		
			95.56	15	5699	4836	4594	4410	4145	3524	3171	2696		
			106.40	14	5699	4836	4594	4410	4145	3524	3171	2696		
			114.86	13	5699	4836	4594	4410	4145	3524	3171	2696		
			124.71	12	5699	4836	4594	4410	4145	3524	3171	2696		
			137.11	11	5372	4558	4330	4157	3908	3322	2989	2541		
			143.25	10	5372	4558	4330	4157	3908	3322	2989	2541		
			153.54	9	4610	3912	3716	3567	3353	2850	2565	2181		
			167.06	9	5372	4558	4330	4157	3908	3322	2989	2541		
			188.01	8	4610	3912	3716	3567	3353	2850	2565	2181		
			205.60	7	5372	4558	4330	4157	3908	3322	2989	2541		
230.23	6	4610	3912	3716	3567	3353	2850	2565	2181					
4V07	4	1440	232.72	6	5699	4836	4594	4410	4145	3524	3171	2696	80-112	7.5
			261.81	6	5699	4836	4594	4410	4145	3524	3171	2696		
			327.69	4	5699	4836	4594	4410	4145	3524	3171	2696		
			378.66	4	5699	4836	4594	4410	4145	3524	3171	2696		
			436.91	3	5699	4836	4594	4410	4145	3524	3171	2696		
			481.08	3	5372	4558	4330	4157	3908	3322	2989	2541		
			525.92	3	5699	4836	4594	4410	4145	3524	3171	2696		
			578.22	2	5372	4558	4330	4157	3908	3322	2989	2541		
			632.11	2	5699	4836	4594	4410	4145	3524	3171	2696		
			664.63	2	5372	4558	4330	4157	3908	3322	2989	2541		
			694.98	2	5372	4558	4330	4157	3908	3322	2989	2541		
			717.84	2	5699	4836	4594	4410	4145	3524	3171	2696		
			743.06	2	4610	3912	3716	3567	3353	2850	2565	2181		
			789.24	2	5372	4558	4330	4157	3908	3322	2989	2541		
			841.36	2	5699	4836	4594	4410	4145	3524	3171	2696		
			883.80	2	4610	3912	3716	3567	3353	2850	2565	2181		
			925.04	2	5372	4558	4330	4157	3908	3322	2989	2541		
			958.59	2	5372	4558	4330	4157	3908	3322	2989	2541		
1035.87	1	4610	3912	3716	3567	3353	2850	2565	2181					
1073.44	1	4610	3912	3716	3567	3353	2850	2565	2181					



1.5 SELECTION TABLE

MODEL	No. OF STAGES	INPUT SPEED	RATIO	OUTPUT SPEED	PEAK TORQUE, Tmax(Nm)	NOMINAL OUTPUT TORQUE, Tn (Nm)							HOL. INPUT FRAME SIZE	THERMAL RATING kW
						n2xh	n2xh	n2xh	n2xh	n2xh	n2xh	n2xh		
						10000	25000	50000	100000	500000	1000000	5000000		
1V08)	1	1440	3.69	390.2	7475	6342	6025	5784	5437	4621	4159	3535	160-200	25.0
			4.04	356.4	8517	7227	6865	6591	6195	5266	4739	4029		
			4.50	320.0	7140	6058	5755	5525	5193	4414	3973	3377		
			5.12	281.3	5879	4988	4739	4549	4276	3635	3271	2781		
			6.00	240.0	4203	3566	3388	3252	3057	2598	2339	1988		
			7.36	195.7	2660	2257	2144	2058	1935	1645	1480	1258		
2V08	2	1440	14.43	99.8	7475	6342	6025	5784	5437	4621	4159	3535	132-180	20.0
			16.32	88.2	8517	7227	6865	6591	6195	5266	4739	4029		
			17.57	82.0	8517	7227	6865	6591	6195	5266	4739	4029		
			19.96	72.1	8517	7227	6865	6591	6195	5266	4739	4029		
			20.68	69.6	8517	7227	6865	6591	6195	5266	4739	4029		
			22.23	64.8	7140	6058	5755	5525	5193	4414	3973	3377		
			24.24	59.4	8517	7227	6865	6591	6195	5266	4739	4029		
			28.64	50.3	8517	7227	6865	6591	6195	5266	4739	4029		
			33.12	43.5	7140	6058	5755	5525	5193	4414	3973	3377		
			37.68	38.2	5879	4988	4739	4549	4276	3635	3271	2781		
3V08	3	1440	53.24	27.0	7475	6342	6025	5784	5437	4621	4159	3535	100-132	10.0
			65.94	21.8	8517	7227	6865	6591	6195	5266	4739	4029		
			73.45	19.6	8517	7227	6865	6591	6195	5266	4739	4029		
			80.63	17.9	8517	7227	6865	6591	6195	5266	4739	4029		
			86.82	16.6	8517	7227	6865	6591	6195	5266	4739	4029		
			94.50	15.2	8517	7227	6865	6591	6195	5266	4739	4029		
			103.78	13.9	8517	7227	6865	6591	6195	5266	4739	4029		
			121.50	11.9	7140	6058	5755	5525	5193	4414	3973	3377		
			145.44	9.9	8517	7227	6865	6591	6195	5266	4739	4029		
			165.85	8.7	8517	7227	6865	6591	6195	5266	4739	4029		
			178.41	8.1	8517	7227	6865	6591	6195	5266	4739	4029		
			191.43	7.5	7140	6058	5755	5525	5193	4414	3973	3377		
			226.21	6.4	7140	6058	5755	5525	5193	4414	3973	3377		
			243.76	5.9	7140	6058	5755	5525	5193	4414	3973	3377		
267.17	5.4	5879	4988	4739	4549	4276	3635	3271	2781					
4V08	4	1440	218.56	6.6	7475	6342	6025	5784	5437	4621	4159	3535	90-112	7.5
			249.89	5.8	7475	6342	6025	5784	5437	4621	4159	3535		
			286.84	5.0	8517	7227	6865	6591	6195	5266	4739	4029		
			325.74	4.4	8517	7227	6865	6591	6195	5266	4739	4029		
			355.87	4.0	8517	7227	6865	6591	6195	5266	4739	4029		
			404.14	3.6	8517	7227	6865	6591	6195	5266	4739	4029		
			434.03	3.3	7475	6342	6025	5784	5437	4621	4159	3535		
			467.51	3.1	8517	7227	6865	6591	6195	5266	4739	4029		
			527.61	2.7	7140	6058	5755	5525	5193	4414	3973	3377		
			558.96	2.6	7475	6342	6025	5784	5437	4621	4159	3535		
			592.43	2.4	7475	6342	6025	5784	5437	4621	4159	3535		
			633.36	2.3	7475	6342	6025	5784	5437	4621	4159	3535		
			659.95	2.2	8517	7227	6865	6591	6195	5266	4739	4029		
			694.32	2.1	8517	7227	6865	6591	6195	5266	4739	4029		
			772.40	1.9	7140	6058	5755	5525	5193	4414	3973	3377		
			861.44	1.7	7140	6058	5755	5525	5193	4414	3973	3377		
			977.06	1.5	7140	6058	5755	5525	5193	4414	3973	3377		
			1112.90	1.3	7475	6342	6025	5784	5437	4621	4159	3535		
			1218.50	1.2	8517	7227	6865	6591	6195	5266	4739	4029		
			1357.20	1.1	7140	6058	5755	5525	5193	4414	3973	3377		



1.5 SELECTION TABLE

MODEL	No. OF STAGES	INPUT SPEED	RATIO	OUTPUT SPEED	PEAK TORQUE, Tmax(Nm)	NOMINAL OUTPUT TORQUE, Tn (Nm)							HOL. INPUT FRAME SIZE	THERMAL RATING kW
						n2xh	n2xh	n2xh	n2xh	n2xh	n2xh	n2xh		
						10000	25000	50000	100000	500000	1000000	5000000		
1V09)	1	1440	3.69	390.2	13332	11312	10746	10317	9698	8243	7419	6306	132-250	40.0
			4.04	356.4	14380	12201	11591	11127	10460	8891	8002	6801		
			4.50	320.0	11575	9821	9330	8957	8419	7156	6441	5475		
			5.12	281.3	9801	8316	7900	7584	7129	6060	5454	4636		
			6.00	240.0	7227	6132	5825	5592	5257	4468	4021	3418		
			7.36	195.7	4868	4130	3924	3767	3541	3009	2709	2302		
2V09	2	1440	14.43	99.8	13332	11312	10746	10317	9698	8243	7419	6306	112-180	25.0
			16.32	88.2	14380	12201	11591	11127	10460	8891	8002	6801		
			17.57	82.0	14380	12201	11591	11127	10460	8891	8002	6801		
			19.96	72.1	14380	12201	11591	11127	10460	8891	8002	6801		
			20.68	69.6	14380	12201	11591	11127	10460	8891	8002	6801		
			22.23	64.8	11575	9821	9330	8957	8419	7156	6441	5475		
			24.24	59.4	14380	12201	11591	11127	10460	8891	8002	6801		
			28.64	50.3	14380	12201	11591	11127	10460	8891	8002	6801		
			33.12	43.5	11575	9821	9330	8957	8419	7156	6441	5475		
37.68	38.2	9801	8316	7900	7584	7129	6060	5454	4636					
3V09	3	1440	53.24	27.0	13332	11312	10746	10317	9698	8243	7419	6306	90-132	15.0
			65.94	21.8	14380	12201	11591	11127	10460	8891	8002	6801		
			73.45	19.6	14380	12201	11591	11127	10460	8891	8002	6801		
			80.63	17.9	14380	12201	11591	11127	10460	8891	8002	6801		
			86.82	16.6	14380	12201	11591	11127	10460	8891	8002	6801		
			94.50	15.2	14380	12201	11591	11127	10460	8891	8002	6801		
			103.78	13.9	14380	12201	11591	11127	10460	8891	8002	6801		
			121.50	11.9	11571	9818	927	8954	8417	7154	6439	5473		
			145.44	9.9	14380	12201	11591	11127	10460	8891	8002	6801		
			165.85	8.7	14380	12201	11591	11127	10460	8891	8002	6801		
			178.41	8.1	14380	12201	11591	11127	10460	8891	8002	6801		
			191.43	7.5	11575	9821	9330	8957	8419	7156	6441	5475		
			226.21	6.4	11575	9821	9330	8957	8419	7156	6441	5475		
			243.76	5.9	11575	9821	9330	8957	8419	7156	6441	5475		
267.17	5.4	9801	8316	7900	7584	7129	6060	5454	4636					
4V09	4	1440	218.56	6.6	13332	11312	10746	10317	9698	8243	7419	6306	90-132	10
			249.89	5.8	13332	11312	10746	10317	9698	8243	7419	6306		
			286.84	5.0	14380	12201	11591	11127	10460	8891	8002	6801		
			325.74	4.4	14380	12201	11591	11127	10460	8891	8002	6801		
			355.87	4.0	14380	12201	11591	11127	10460	8891	8002	6801		
			404.14	3.6	14380	12201	11591	11127	10460	8891	8002	6801		
			434.03	3.3	13134	11144	10587	10163	9554	8120	7308	6212		
			467.51	3.1	14380	12201	11591	11127	10460	8891	8002	6801		
			527.61	2.7	11575	9821	9330	8957	8419	7156	6441	5475		
			558.96	2.6	13332	11312	10746	10317	9698	8243	7419	6306		
			592.43	2.4	13332	11312	10746	10317	9698	8243	7419	6306		
			633.36	2.3	13332	11312	10746	10317	9698	8243	7419	6306		
			659.95	2.2	14380	12201	11591	11127	10460	8891	8002	6801		
			694.32	2.1	14380	12201	11591	11127	10460	8891	8002	6801		
			772.40	1.9	11575	9821	9330	8957	8419	7156	6441	5475		
			861.44	1.7	11575	9821	9330	8957	8419	7156	6441	5475		
			977.06	1.5	11575	9821	9330	8957	8419	7156	6441	5475		
			1112.90	1.3	13332	11312	10746	10317	9698	8243	7419	6306		
1218.50	1.2	14380	12201	11591	11127	10460	8891	8002	6801					
1357.20	1.1	11575	9821	9330	8957	8419	7156	6441	5475					



1.5 SELECTION TABLE

MODEL	No. OF STAGES	INPUT SPEED	RATIO	OUTPUT SPEED	PEAK TORQUE, Tmax(Nm)	NOMINAL OUTPUT TORQUE, Tn (Nm)							HOL. INPUT FRAME SIZE	THERMAL RATING kW
						n2xh	n2xh	n2xh	n2xh	n2xh	n2xh	n2xh		
						10000	25000	50000	100000	500000	1000000	5000000		
1V10	1	1440	3.69	390.2	20201	17140	15426	14809	13921	11832	10649	9052	160-250	50.0
			4.04	356.4	21681	18396	17476	16777	15771	13405	12064	10255		
			4.50	320.0	18218	15457	14685	14097	13251	11264	10137	8617		
			5.12	281.3	14840	12592	11962	11484	10795	9175	8258	7019		
			6.00	240.0	10504	8912	8467	8128	7640	6494	5845	4968		
			7.36	195.7	6849	5811	5521	5300	4982	4235	3811	3240		
2V01	2	1440	14.43	99.8	20201	17140	16283	15632	14694	12490	11241	9555	132-200	25.0
			16.32	88.2	21681	18396	17476	16777	15771	13405	12064	10255		
			17.57	82.0	21681	18396	17476	16777	15771	13405	12064	10255		
			19.96	72.1	21681	18396	17476	16777	15771	13405	12064	10255		
			20.68	69.6	21681	18396	17476	16777	15771	13405	12064	10255		
			22.23	64.8	18218	15457	14685	14097	13251	11264	10137	8617		
			24.24	59.4	21681	18396	17476	16777	15771	13405	12064	10255		
			28.64	50.3	21681	18396	17476	16777	15771	13405	12064	10255		
			33.12	43.5	18218	15457	14685	14097	13251	11264	10137	8617		
37.68	38.2	14840	12592	11962	11484	10795	9175	8258	7019					
3V10	3	1440	53.24	27.0	20201	17140	16283	15632	14694	12490	11241	9555	132-180	15.0
			65.94	21.8	21681	18396	17476	16777	15771	13405	12064	10255		
			73.45	19.6	21681	18396	17476	16777	15771	13405	12064	10255		
			80.63	17.9	21681	18396	17476	16777	15771	13405	12064	10255		
			86.82	16.6	21681	18396	17476	16777	15771	13405	12064	10255		
			94.50	15.2	21681	18396	17476	16777	15771	13405	12064	10255		
			103.78	13.9	21681	18396	17476	16777	15771	13405	12064	10255		
			121.50	11.9	18218	15457	14685	14097	13251	11264	10137	8617		
			145.44	9.9	21681	18396	17476	16777	15771	13405	12064	10255		
			165.85	8.7	21681	18396	17476	16777	15771	13405	12064	10255		
			178.41	8.1	21681	18396	17476	16777	15771	13405	12064	10255		
			191.43	7.5	18218	15457	14685	14097	13251	11264	10137	8617		
			226.21	6.4	18218	15457	14685	14097	13251	11264	10137	8617		
			243.76	5.9	18218	15457	14685	14097	13251	11264	10137	8617		
267.17	5.4	14840	12592	11962	11484	10795	9175	8258	7019					
4V10	4	1440	218.56	6.6	20201	17140	16283	15632	14694	12490	11241	9555	100-132	12.5
			249.89	5.8	20201	17140	16283	15632	14694	12490	11241	9555		
			286.84	5.0	21681	18396	17476	16777	15771	13405	12064	10255		
			325.74	4.4	21681	18396	17476	16777	15771	13405	12064	10255		
			355.87	4.0	21681	18396	17476	16777	15771	13405	12064	10255		
			404.14	3.6	21681	18396	17476	16777	15771	13405	12064	10255		
			434.03	3.3	20201	17140	16283	15632	14694	12490	11241	9555		
			467.51	3.1	21681	18396	17476	16777	15771	13405	12064	10255		
			527.61	2.7	18218	15457	14685	14097	13251	11264	10137	8617		
			558.96	2.6	20201	17140	16283	15632	14694	12490	11241	9555		
			592.43	2.4	20201	17140	16283	15632	14694	12490	11241	9555		
			633.36	2.3	20201	17140	16283	15632	14694	12490	11241	9555		
			659.95	2.2	21681	18396	17476	16777	15771	13405	12064	10255		
			694.32	2.1	21681	18396	17476	16777	15771	13405	12064	10255		
			772.40	1.9	18218	15457	14685	14097	13251	11264	10137	8617		
			861.44	1.7	18218	15457	14685	14097	13251	11264	10137	8617		
			977.06	1.5	18218	15457	14685	14097	13251	11264	10137	8617		
			1112.90	1.3	20201	17140	16283	15632	14694	12490	11241	9555		
1218.50	1.2	21681	18396	17476	16777	15771	13405	12064	10255					
1357.20	1.1	18218	15457	14685	14097	13251	11264	10137	8617					

1.6 SELECTION TABLE

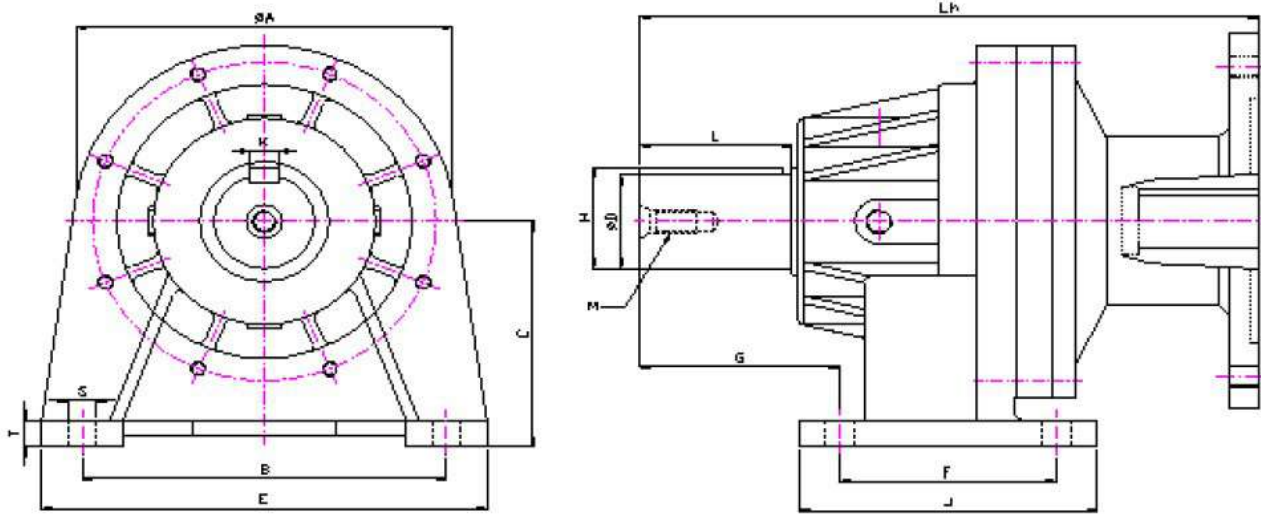

DIMENSIONS OF FOOT MOUNTED HOLLOW INPUT

MODEL	OUTPUT SHAFT					FOOT MOUNTING							OTHERS			
	D j6	L	H	K p9	M	B	E	T	C	F	J	G	S	A		Lh
1V02	19	30	21.5	6	M6	95	120	10	80	65	85	44	9	95	180	SINGLE STAGE
1V22	24	38	27.0	8	M6	110	140	12	90	80	110	54	11	110	199	
1V03	28	40	31.0	8	M8	120	155	12	100	90	125	57	13	135	224	
1V04	38	50	41.0	10	M10	140	175	12	105	95	130	72	14	155	263	
1V05	50	75	53.5	14	M12	180	220	14	120	110	150	97	14	185	306	
1V55	55	80	59.0	16	M12	200	240	16	135	130	170	104	14	215	341	
1V06	60	90	64.0	18	M16	210	260	18	150	140	190	108	18	235	369	
1V07	70	90	74.5	20	M16	240	290	18	160	160	210	114	18	265	395	
1V08	80	110	85.5	22	M16	270	330	18	170	170	230	135	18	290	394	
2V02	19	30	21.5	6	M6	95	120	10	80	65	85	44	9	95	208	DOUBLE STAGE
2V22	24	38	27.0	8	M6	110	140	12	90	80	110	54	11	110	230	
2V03	28	40	31.0	8	M8	120	155	12	100	90	125	57	13	135	257	
2V04	38	50	41.0	10	M10	140	175	12	105	95	130	72	14	155	303	
2V05	50	75	53.5	14	M12	180	220	14	120	110	150	97	14	185	353	
2V55	55	80	59.0	16	M12	200	240	16	135	130	170	104	14	215	399	
2V06	60	90	64.0	18	M16	210	260	18	150	140	190	108	18	235	424	
2V07	70	90	74.5	20	M16	240	290	18	160	160	210	114	18	265	468	
2V08	80	110	85.5	22	M16	270	330	18	170	170	230	135	18	290	394	
3V02	19	30	21.5	6	M6	95	120	10	80	65	85	44	9	95	229	TRIPLE STAGE
3V22	24	38	27.0	8	M6	110	140	12	90	80	110	54	11	110	255	
3V03	28	40	31.0	8	M8	120	155	12	100	90	125	57	13	135	274	
3V04	38	50	41.0	10	M10	140	175	12	105	95	130	72	14	155	313	
3V05	50	75	53.5	14	M12	180	220	14	120	110	150	97	14	185	376	
3V55	55	80	59.0	16	M12	200	240	16	135	130	170	104	14	215	394	
3V06	60	90	64.0	18	M16	210	260	18	150	140	190	108	18	235	439	
3V07	70	90	74.5	20	M16	240	290	18	160	160	210	114	18	265	495	
3V08	80	110	85.5	22	M16	270	330	18	170	170	230	135	18	290	394	
4V02	19	30	21.5	6	M6	95	120	10	80	65	85	44	9	95	264	FOURTH STAGE
4V22	24	38	27.0	8	M6	110	140	12	90	80	110	54	11	110	283	
4V03	28	40	31.0	8	M8	120	155	12	100	90	125	57	13	135	302	
4V04	38	50	41.0	10	M10	140	175	12	105	95	130	72	14	155	340	
4V05	50	75	53.5	14	M12	180	220	14	120	110	150	97	14	185	399	
4V55	55	80	59.0	16	M12	200	240	16	135	130	170	104	14	215	421	
4V06	60	90	64.0	18	M16	210	260	18	150	140	190	108	18	235	466	
4V07	70	90	74.5	20	M16	240	290	18	160	160	210	114	18	265	538	
4V08	80	110	85.5	22	M16	270	330	18	170	170	230	135	18	290	394	



1.6 SELECTION TABLE

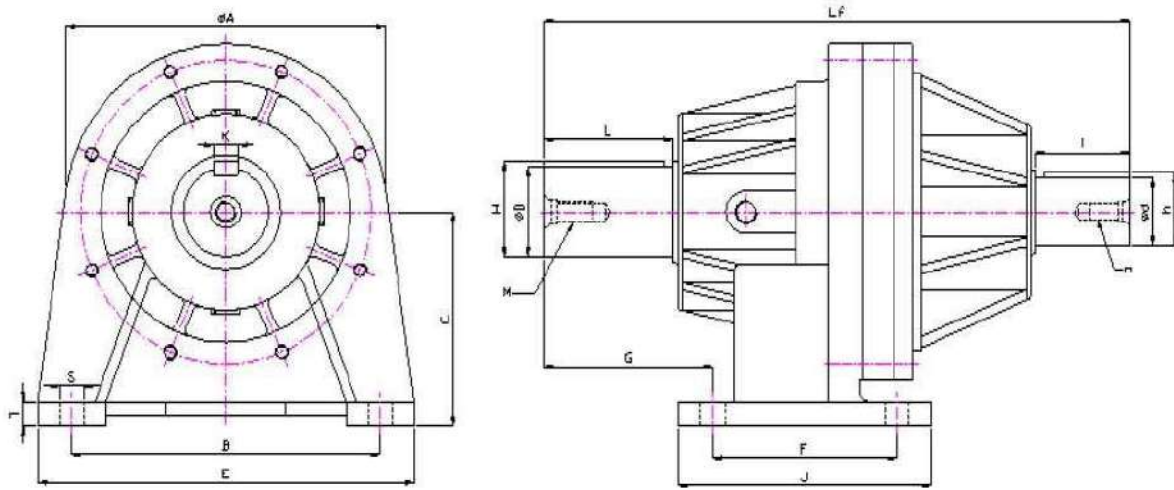

DIMENSIONS OF FOOT MOUNTED FREE INPUT

MODEL	OUTPUT SHAFT					INPUT SHAFT					FOOT MOUNTING							OTHERS			
	D j6	L	H	K p9	M	d j6	l	h	k p9	m	B	E	T	C	F	J	G	S	A		Lf
3005	19	30	21.5	6	M6	14	20	16.0	5	M5	95	120	10	80	65	85	44	9	95	178	FIRST STAGE
3010	24	38	27.0	8	M6	19	30	21.5	6	M6	110	140	12	90	80	110	54	11	110	215	
3020	28	40	31.0	8	M8	24	35	27.0	8	M6	120	155	12	100	90	125	57	13	135	240	
3030	38	50	41.0	10	M10	28	40	31.0	8	M8	140	175	12	105	95	130	72	14	155	280	
3040	50	75	53.5	14	M12	38	50	41.0	10	M10	180	220	14	120	110	150	97	14	185	337	
3045	55	80	59.0	16	M12	42	55	45.0	12	M12	200	240	16	135	130	170	104	14	215	368	
3050	60	90	64.0	18	M16	50	75	53.5	14	M12	210	260	18	150	140	190	108	18	235	405	
3055	70	90	74.5	20	M16	50	75	53.5	14	M12	240	290	18	160	160	210	114	18	265	446	
3060	80	110	85.5	22	M16	60	90	64.0	18	M16	270	330	18	170	170	230	135	18	290	446	
MODEL	OUTPUT SHAFT					INPUT SHAFT					FOOT MOUNTING							OTHERS			
D j6	L	D1	K p9	M	d j6	l	h	k p9	m	B	E	T	C	F	J	G	S	A	Lf		
3005	19	30	21.5	6	M6	14	20	16.0	5	M5	95	120	10	80	65	85	44	9	95	206	DOUBLE STAGE
3010	24	38	27.0	8	M6	14	20	16.0	5	M5	110	140	12	90	80	110	54	11	110	225	
3020	28	40	31.0	8	M8	19	30	21.5	6	M6	120	155	12	100	90	125	57	13	135	263	
3030	38	50	41.0	10	M10	24	35	27.0	8	M6	140	175	12	105	95	130	72	14	155	306	
3040	50	75	53.5	14	M12	28	40	31.0	8	M8	180	220	14	120	110	150	97	14	185	366	
3045	55	80	59.0	16	M12	28	40	31.0	8	M8	200	240	16	135	130	170	104	14	215	405	
3050	60	90	64.0	18	M16	38	50	41.0	10	M10	210	260	18	150	140	190	108	18	235	427	
3055	70	90	74.5	20	M16	50	75	53.5	14	M12	240	290	18	160	160	210	114	18	265	504	
3060	80	110	85.5	22	M16	50	75	53.5	14	M12	270	330	18	170	170	230	135	18	290	446	
MODEL	OUTPUT SHAFT					INPUT SHAFT					FOOT MOUNTING							OTHERS			
D j6	L	D1	K p9	M	d j6	l	h	k p9	m	B	E	T	C	F	J	G	S	A	Lf		
3005	19	30	21.5	6	M6	14	20	16.0	5	M5	95	120	10	80	65	85	44	9	95	234	TRIPPLE STAGE
3010	24	38	27.0	8	M6	14	20	16.0	5	M5	110	140	12	90	80	110	54	11	110	253	
3020	28	40	31.0	8	M8	14	20	16.0	5	M5	120	155	12	100	90	125	57	13	135	272	
3030	38	50	41.0	10	M10	19	30	21.5	6	M6	140	175	12	105	95	130	72	14	155	329	
3040	50	75	53.5	14	M12	24	35	27.0	8	M6	180	220	14	120	110	150	97	14	185	392	
3045	55	80	59.0	16	M12	24	35	27.0	8	M6	200	240	16	135	130	170	104	14	215	428	
3050	60	90	64.0	18	M16	28	40	31.0	8	M8	210	260	18	150	140	190	108	18	235	456	
3055	70	90	74.5	20	M16	38	50	41.0	10	M10	240	290	18	160	160	210	114	18	265	526	
3060	80	110	85.5	22	M16	38	50	41.0	10	M10	270	330	18	170	170	230	135	18	290	446	
MODEL	OUTPUT SHAFT					INPUT SHAFT					FOOT MOUNTING							OTHERS			
D j6	L	D1	K p9	M	d j6	l	h	k p9	m	B	E	T	C	F	J	G	S	A	Lf		
3005	19	30	21.5	6	M6	14	20	16.0	5	M5	95	120	10	80	65	85	44	9	95	262	FOURTH STAGE
3010	24	38	27.0	8	M6	14	20	16.0	5	M5	110	140	12	90	80	110	54	11	110	281	
3020	28	40	31.0	8	M8	14	20	16.0	5	M5	120	155	12	100	90	125	57	13	135	300	
3030	38	50	41.0	10	M10	14	20	16.0	5	M5	140	175	12	105	95	130	72	14	155	338	
3040	50	75	53.5	14	M12	19	30	21.5	6	M6	180	220	14	120	110	150	97	14	185	415	
3045	55	80	59.0	16	M12	24	35	27.0	8	M6	200	240	16	135	130	170	104	14	215	456	
3050	60	90	64.0	18	M16	24	35	27.0	8	M6	210	260	18	150	140	190	108	18	235	492	
3055	70	90	74.5	20	M16	28	40	31.0	8	M8	240	290	18	160	160	210	114	18	265	555	
3060	80	110	85.5	22	M16	28	40	31.0	8	M8	270	330	18	170	170	230	135	18	290	446	

1.6 SELECTION TABLE

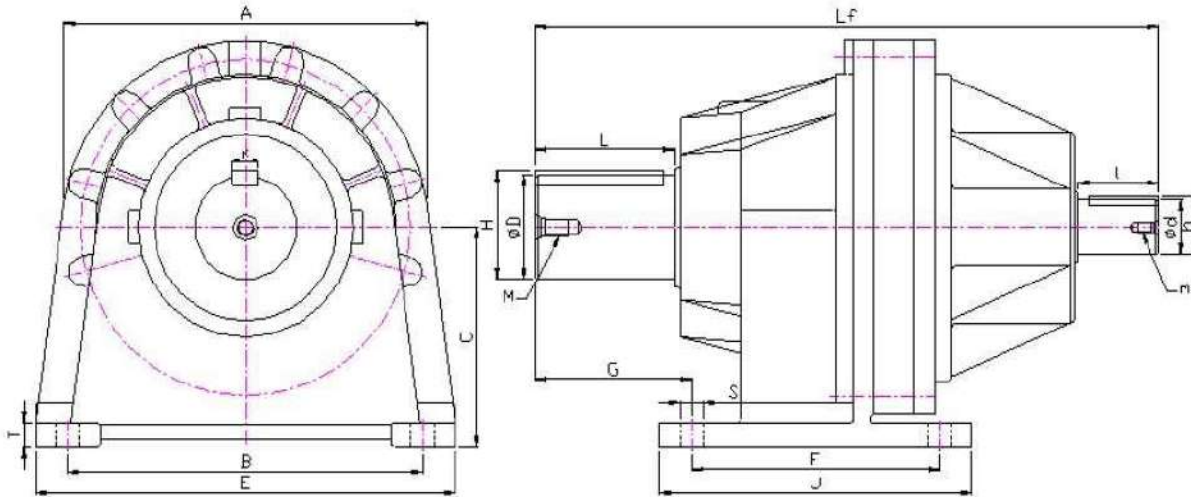

DIMENSIONS OF FOOT MOUNTED FREE INPUT																					
MODEL	OUTPUT SHAFT					INPUT SHAFT					FOOT MOUNTING							OTHERS			
	D j6	L	H	K p9	M	d j6	l	h	k p9	m	B	E	T	C	F	J	G	S	A		Lf
3070	95	130	100.0	25	M16	70	100	74.5	20	M16	330	390	22	200	230	290	163	22	340	546	SINGLE STAGE
3080	110	170	116.0	28	M20	70	100	74.5	20	M16	380	440	25	225	280	340	200	22	385	655	
3090	120	180	127.0	32	M20	90	120	95	20	M16	400	480	30	260	300	380	232	26	435	745	
MODEL	OUTPUT SHAFT					INPUT SHAFT					FOOT MOUNTING							OTHERS			
D j6	L	D1	K p9	M	d j6	l	h	k p9	m	B	E	T	C	F	J	G	S	A	Lf		
3070	95	130	100.0	25	M16	70	100	74.5	20	M16	330	390	22	200	230	290	163	22	340	615	DOUBLE STAGE
3080	110	170	116.0	28	M20	70	100	74.5	20	M16	380	440	25	225	280	340	200	22	385	711	
3090	120	180	127.0	32	M20	90	120	95	20	M16	400	480	30	260	300	380	232	26	435	825	
MODEL	OUTPUT SHAFT					INPUT SHAFT					FOOT MOUNTING							OTHERS			
D j6	L	D1	K p9	M	d j6	l	h	k p9	m	B	E	T	C	F	J	G	S	A	Lf		
3070	95	130	100.0	25	M16	70	100	74.5	20	M16	330	390	22	200	230	290	163	22	340	681	TRIPPLE STAGE
3080	110	170	116.0	28	M20	70	100	74.5	20	M16	380	440	25	225	280	340	200	22	385	780	
3090	120	180	127.0	32	M20	90	120	95	20	M16	400	480	30	260	300	380	232	26	435	885	
MODEL	OUTPUT SHAFT					INPUT SHAFT					FOOT MOUNTING							OTHERS			
D j6	L	D1	K p9	M	d j6	l	h	k p9	m	B	E	T	C	F	J	G	S	A	Lf		
3070	95	130	100.0	25	M16	70	100	74.5	20	M16	330	390	22	200	230	290	163	22	340	739	FOURTH STAGE
3080	110	170	116.0	28	M20	70	100	74.5	20	M16	380	440	25	225	280	340	200	22	385	846	
3090	120	180	127.0	32	M20	90	120	95	20	M16	400	480	30	260	300	380	232	26	435	948	



1.6 SELECTION TABLE

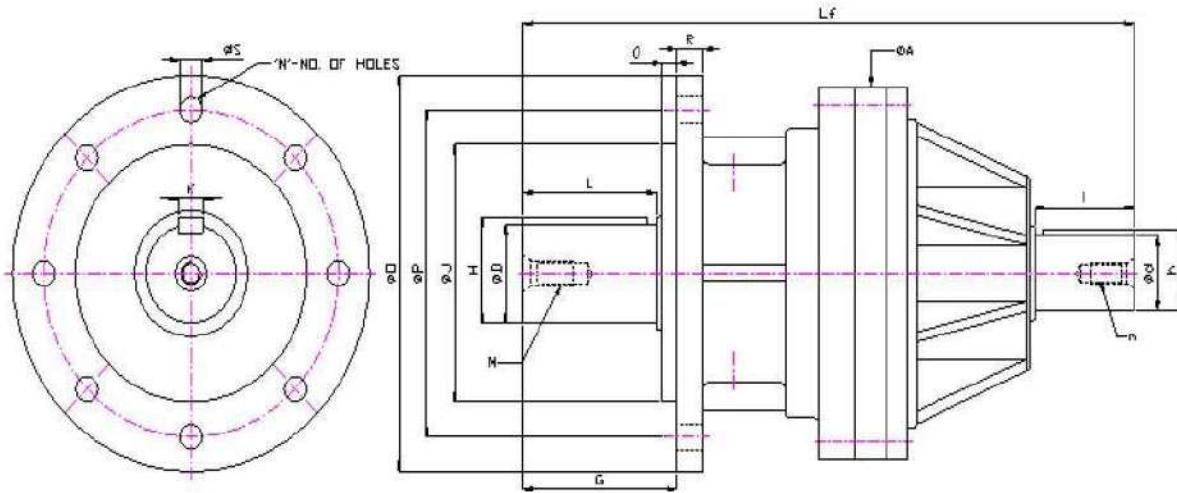

DIMENSIONS OF FLANGE MOUNTED FREE INPUT																				
MODEL	OUTPUT SHAFT					INPUT SHAFT					FLANGE MOUNTING							OTHERS		
	D j6	L	H	K p9	M	d j6	l	h	k p9	m	J	O	Q	R	P	G	S	N	A	Lf
3005	19	30	21.5	6	M6	14	20	16.0	5	M5	60	100	3	10	80	35	9	4	95	178
3010	24	38	27.0	8	M6	19	30	21.5	6	M6	80	120	3	11	100	43	11	4	110	215
3020	28	40	31.0	8	M8	24	35	27.0	8	M6	90	145	4	12	120	47	13	4	135	240
3030	38	50	41.0	10	M10	28	40	31.0	8	M8	110	160	5	12	135	58	9	8	155	280
3040	50	75	53.5	14	M12	38	50	41.0	10	M10	130	195	8	15	165	86	11	8	185	337
3045	55	80	59.0	16	M12	42	55	45.0	12	M12	145	215	9	16	180	92	13	8	215	368
3050	60	90	64.0	18	M16	50	75	53.5	14	M12	160	240	10	18	200	103	13	8	235	405
3055	70	90	74.5	20	M16	50	75	53.5	14	M12	180	265	10	18	225	103	13	8	265	446
3060	80	110	85.5	22	M16	50	75	53.5	14	M12	235	290	10	23	265	123	14	8	290	461
MODEL	OUTPUT SHAFT					INPUT SHAFT					FLANGE MOUNTING							OTHERS		
	D j6	L	H	K p9	M	d j6	l	h	k p9	m	J	O	Q	R	P	G	S	N	A	Lf
3005	19	30	21.5	6	M6	14	20	16.0	5	M5	60	100	3	10	80	35	9	4	95	206
3010	24	38	27.0	8	M6	14	20	16.0	5	M5	80	120	3	11	100	43	11	4	110	225
3020	28	40	31.0	8	M8	19	30	21.5	6	M6	90	145	4	12	120	47	13	4	135	263
3030	38	50	41.0	10	M10	24	35	27.0	8	M6	110	160	5	12	135	58	9	8	155	306
3040	50	75	53.5	14	M12	28	40	31.0	8	M8	130	195	8	15	165	86	11	8	185	366
3045	55	80	59.0	16	M12	28	40	31.0	8	M8	145	215	9	16	180	92	13	8	215	396
3050	60	90	64.0	18	M16	38	50	41.0	10	M10	160	240	10	18	200	103	13	8	235	427
3055	70	90	74.5	20	M16	50	75	53.5	14	M12	180	265	10	18	225	103	13	8	265	504
3060	80	110	85.5	22	M16	50	75	53.5	14	M12	235	290	10	23	265	123	14	8	290	570
MODEL	OUTPUT SHAFT					INPUT SHAFT					FLANGE MOUNTING							OTHERS		
	D j6	L	H	K p9	M	d j6	l	h	k p9	m	J	O	Q	R	P	G	S	N	A	Lf
3005	19	30	21.5	6	M6	14	20	16.0	5	M5	60	100	3	10	80	35	9	4	95	234
3010	24	38	27.0	8	M6	14	20	16.0	5	M5	80	120	3	11	100	43	11	4	110	253
3020	28	40	31.0	8	M8	14	20	16.0	5	M5	90	145	4	12	120	47	13	4	135	272
3030	38	50	41.0	10	M10	19	30	21.5	6	M6	110	160	5	12	135	58	9	8	155	329
3040	50	75	53.5	14	M12	24	35	27.0	8	M6	130	195	8	15	165	86	11	8	185	392
3045	55	80	59.0	16	M12	24	35	27.0	8	M6	145	215	9	16	180	92	13	8	215	428
3050	60	90	64.0	18	M16	28	40	31.0	8	M8	160	240	10	18	200	103	13	8	235	456
3055	70	90	74.5	20	M16	38	50	41.0	10	M10	180	265	10	18	225	103	13	8	265	526
3060	80	110	85.5	22	M16	38	50	41.0	10	M10	235	290	10	23	265	123	14	8	290	586
MODEL	OUTPUT SHAFT					INPUT SHAFT					FLANGE MOUNTING							OTHERS		
	D j6	L	H	K p9	M	d j6	l	h	k p9	m	J	O	Q	R	P	G	S	N	A	Lf
3005	19	30	21.5	6	M6	14	20	16.0	5	M5	60	100	3	10	80	35	9	4	95	262
3010	24	38	27.0	8	M6	14	20	16.0	5	M5	80	120	3	11	100	43	11	4	110	281
3020	28	40	31.0	8	M8	14	20	16.0	5	M5	90	145	4	12	120	47	13	4	135	300
3030	38	50	41.0	10	M10	14	20	16.0	5	M5	110	160	5	12	135	58	9	8	155	338
3040	50	75	53.5	14	M12	19	30	21.5	6	M6	130	195	8	15	165	86	11	8	185	415
3045	55	80	59.0	16	M12	24	35	27.0	8	M6	145	215	9	16	180	92	13	8	215	456
3050	60	90	64.0	18	M16	24	35	27.0	8	M6	160	240	10	18	200	103	13	8	235	482
3055	70	90	74.5	20	M16	28	40	31.0	8	M8	180	265	10	18	225	103	13	8	265	555
3060	80	110	85.5	22	M16	28	40	31.0	8	M8	235	290	10	23	265	123	14	8	290	625

1.6 SELECTION TABLE

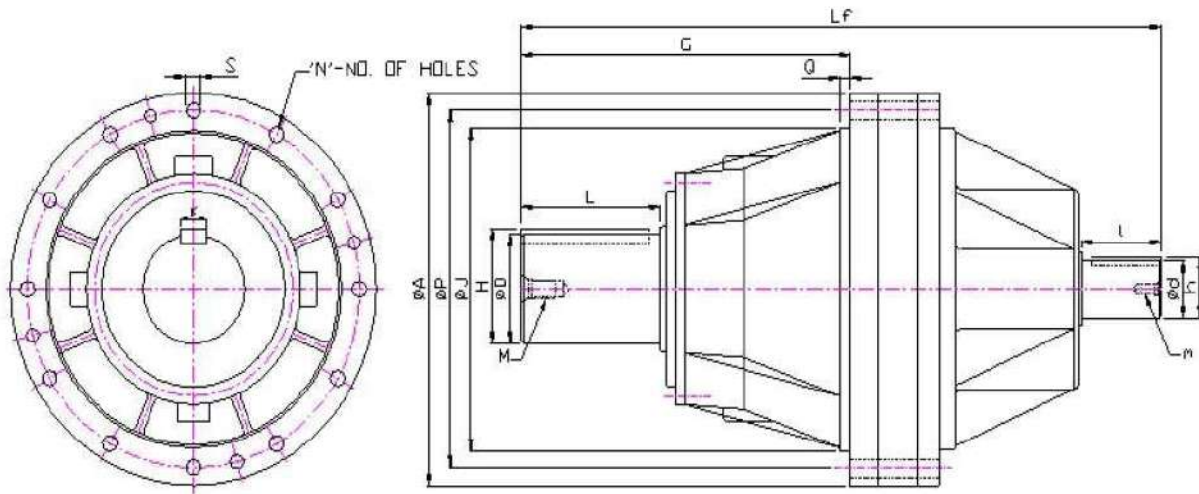

DIMENSIONS OF FLANGE MOUNTED FREE INPUT																			
MODEL	OUTPUT SHAFT					INPUT SHAFT					FLANGE MOUNTING					OTHERS			
	D j6	L	H	K p9	M	d j6	l	h	k p9	m	J	Q	P	G	S	N	A		Lf
3070	90	130	100.0	25	M16	70	100	74.5	20	M16	280	10	310	306	17	12	340	546	SINGLE STAGE
3080	110	170	116.0	28	M20	70	100	74.5	20	M16	320	12	350	378	17	12	385	655	
3090	120	180	127.0	32	M20	90	120	95	20	M16	370	14	400	412	17	16	435	745	
MODEL	OUTPUT SHAFT					INPUT SHAFT					FLANGE MOUNTING					OTHERS			
	D j6	L	H	K p9	M	d j6	l	h	k p9	m	J	Q	P	G	S	N	A		Lf
3070	90	130	100.0	25	M16	70	100	74.5	20	M16	280	10	310	306	17	12	340	615	DOUBLE STAGE
3080	110	170	116.0	28	M20	70	100	74.5	20	M16	320	12	350	378	17	12	385	711	
3090	120	180	127.0	32	M20	90	120	95	20	M16	370	14	400	412	17	16	435	825	
MODEL	OUTPUT SHAFT					INPUT SHAFT					FLANGE MOUNTING					OTHERS			
	D j6	L	H	K p9	M	d j6	l	h	k p9	m	J	Q	P	G	S	N	A		Lf
3070	90	130	100.0	25	M16	70	100	74.5	20	M16	280	10	310	306	17	12	340	681	TRIPPLE STAGE
3080	110	170	116.0	28	M20	70	100	74.5	20	M16	320	12	350	378	17	12	385	780	
3090	120	180	127.0	32	M20	90	120	95	20	M16	370	14	400	412	17	16	435	885	
MODEL	OUTPUT SHAFT					INPUT SHAFT					FLANGE MOUNTING					OTHERS			
	D j6	L	H	K p9	M	d j6	l	h	k p9	m	J	Q	P	G	S	N	A		Lf
3070	90	130	100.0	25	M16	70	100	74.5	20	M16	280	10	310	306	17	12	340	739	FOURTH STAGE
3080	110	170	116.0	28	M20	70	100	74.5	20	M16	320	12	350	378	17	12	385	846	
3090	120	180	127.0	32	M20	90	120	95	20	M16	370	14	400	412	17	16	435	948	



1.6 SELECTION TABLE

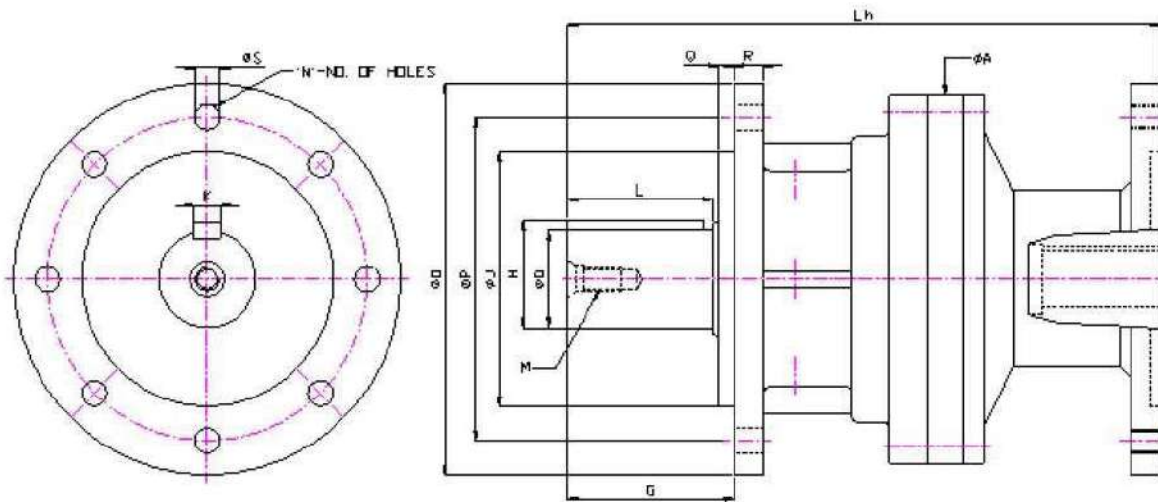

DIMENSIONS OF FLANGE MOUNTED HOLLOW INPUT																
MODEL	OUTPUT SHAFT					FLANGE MOUNTING								OTHERS		
	D j6	L	H	K p9	M	J	O	Q	R	P	G	S	N	A	Lf	
3005	19	30	21.5	6	M6	60	100	3	10	80	35	9	4	95	180	SINGLE STAGE
3010	24	38	27.0	8	M6	80	120	3	11	100	43	11	4	110	199	
3020	28	40	31.0	8	M8	90	145	4	12	120	47	13	4	135	224	
3030	38	50	41.0	10	M10	110	160	5	12	135	58	9	8	155	263	
3040	50	75	53.5	14	M12	130	195	8	15	165	86	11	8	185	306	
3045	55	80	59.0	16	M12	145	215	9	16	180	92	13	8	215	342	
3050	60	90	64.0	18	M16	160	240	10	18	200	103	13	8	235	369	
3055	70	90	74.5	20	M16	180	265	10	18	225	103	13	8	265	395	
3060	80	110	85.5	22	M16	235	290	10	23	265	123	14	8	290	454	
3005	19	30	21.5	6	M6	60	100	3	10	80	35	9	4	95	208	DOUBLE STAGE
3010	24	38	27.0	8	M6	80	120	3	11	100	43	11	4	110	230	
3020	28	40	31.0	8	M8	90	145	4	12	120	47	13	4	135	257	
3030	38	50	41.0	10	M10	110	160	5	12	135	58	9	8	155	303	
3040	50	75	53.5	14	M12	130	195	8	15	165	86	11	8	185	353	
3045	55	80	59.0	16	M12	145	215	9	16	180	92	13	8	215	386	
3050	60	90	64.0	18	M16	160	240	10	18	200	103	13	8	235	424	
3055	70	90	74.5	20	M16	180	265	10	18	225	103	13	8	265	468	
3060	80	110	85.5	22	M16	235	290	10	23	265	123	14	8	290	530	
3005	19	30	21.5	6	M6	60	100	3	10	80	35	9	4	95	229	TRIPPLE STAGE
3010	24	38	27.0	8	M6	80	120	3	11	100	43	11	4	110	255	
3020	28	40	31.0	8	M8	90	145	4	12	120	47	13	4	135	274	
3030	38	50	41.0	10	M10	110	160	5	12	135	58	9	8	155	313	
3040	50	75	53.5	14	M12	130	195	8	15	165	86	11	8	185	376	
3045	55	80	59.0	16	M12	145	215	9	16	180	92	13	8	215	406	
3050	60	90	64.0	18	M16	160	240	10	18	200	103	13	8	235	439	
3055	70	90	74.5	20	M16	180	265	10	18	225	103	13	8	265	495	
3060	80	110	85.5	22	M16	235	290	10	23	265	123	14	8	290	521	
3005	19	30	21.5	6	M6	60	100	3	10	80	35	9	4	95	264	FOURTH STAGE
3010	24	38	27.0	8	M6	80	120	3	11	100	43	11	4	110	283	
3020	28	40	31.0	8	M8	90	145	4	12	120	47	13	4	135	302	
3030	38	50	41.0	10	M10	110	160	5	12	135	58	9	8	155	340	
3040	50	75	53.5	14	M12	130	195	8	15	165	86	11	8	185	399	
3045	55	80	59.0	16	M12	145	215	9	16	180	92	13	8	215	426	
3050	60	90	64.0	18	M16	160	240	10	18	200	103	13	8	235	466	
3055	70	90	74.5	20	M16	180	265	10	18	225	103	13	8	265	538	
3060	80	110	85.5	22	M16	235	290	10	23	265	123	14	8	290	568	

1.6 SELECTION TABLE

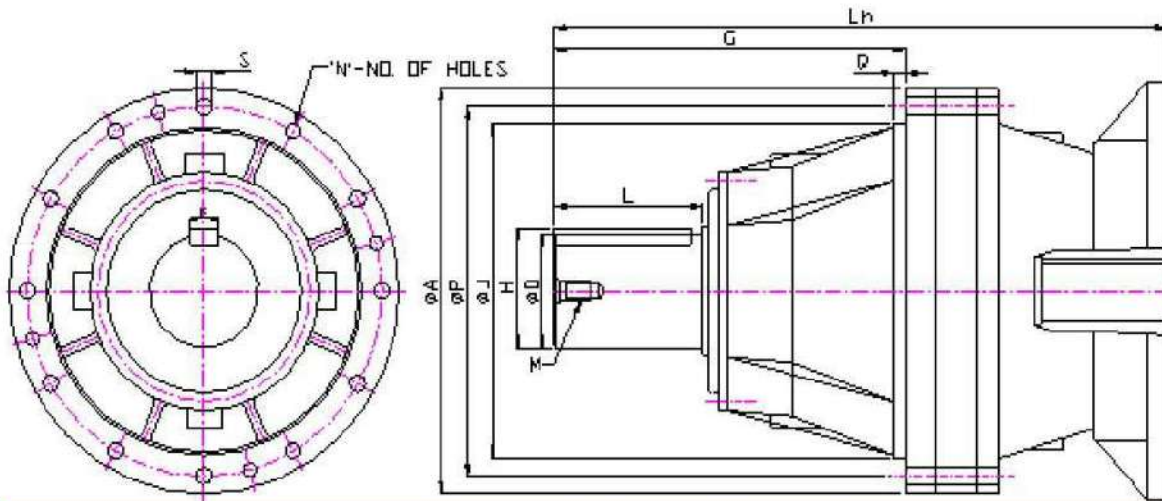

DIMENSIONS OF FLANGE MOUNTED HOLLOW INPUT														
MODEL	OUTPUT SHAFT					FLANGE MOUNTING						OTHERS		
	Dj6	L	H	K p9	M	J	Q	P	G	S	N	A	Lh	
1V09	95	130	100.0	25	M16	280	10	310	306	17	12	340	481	SINGLE STAGE
1V10	110	170	116.0	28	M20	320	12	350	378	17	12	385	587	
1V11	120	180	127.0	32	M20	370	14	400	412	17	16	435	685	
MODEL	OUTPUT SHAFT					FLANGE MOUNTING						OTHERS		
Dj6	L	H	K p9	M	J	Q	P	G	S	N	A	Lh		
2V09	95	130	100.0	25	M16	280	10	310	306	17	12	340	548	DOUBLE STAGE
2V10	110	170	116.0	28	M20	320	12	350	378	17	12	385	646	
2V11	120	180	127.0	32	M20	370	14	400	412	17	16	435	748	
MODEL	OUTPUT SHAFT					FLANGE MOUNTING						OTHERS		
Dj6	L	H	K p9	M	J	Q	P	G	S	N	A	Lh		
3V09	95	130	100.0	25	M16	280	10	310	306	17	12	340	630	TRIPLE STAGE
3V10	110	170	116.0	28	M20	320	12	350	378	17	12	385	713	
3V11	120	180	127.0	32	M20	370	14	400	412	17	16	435	815	
MODEL	OUTPUT SHAFT					FLANGE MOUNTING						OTHERS		
Dj6	L	H	K p9	M	J	Q	P	G	S	N	A	Lh		
4V09	95	130	100.0	25	M16	280	10	310	306	17	12	340	703	FOURTH STAGE
4V10	110	170	116.0	28	M20	320	12	350	378	17	12	385	795	
4V11	120	180	127.0	32	M20	370	14	400	412	17	16	435	905	



1.6 SELECTION TABLE

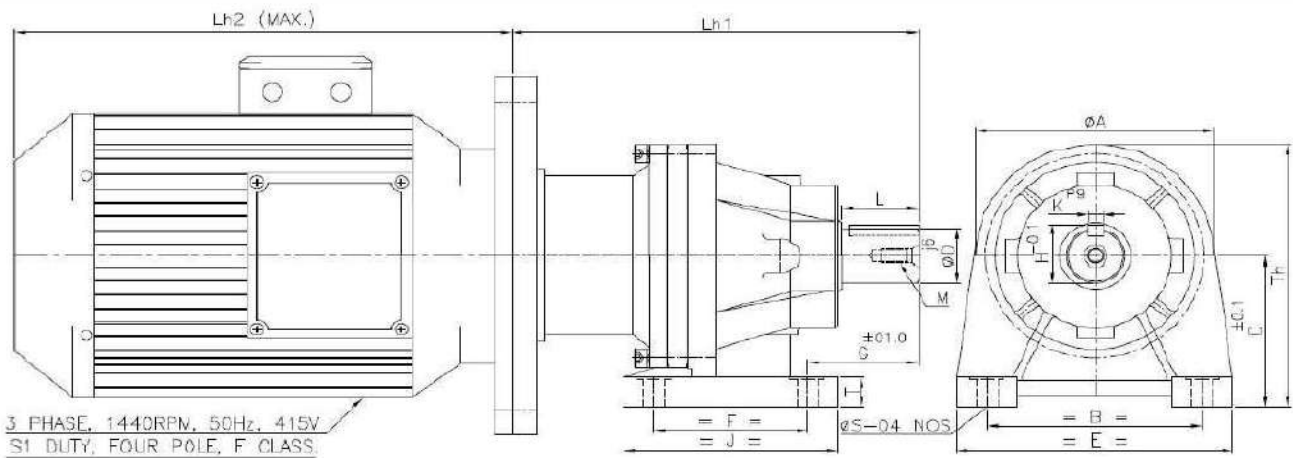

DIMENSIONS OF GEARED MOTOR FOOT MOUNTED

SINGLE STAGE

MODEL	OUTPUT SHAFT					FOOT MOUNTING										OTHERS	
	D j6	L	H	K p9	M	B	E	T	C	F	J	G	S	Th	A	Lh1	
3005	19	30	21.5	6	M6	95	120	14	80	75	100	45	9	127.5	95	183	
3010	24	38	27.0	8	M6	110	140	16	90	85	115	55	11	145	110	203	
3020	28	40	31.0	8	M8	120	160	18	100	90	130	60	12	167.5	135	236	
3030	38	50	41.0	10	M10	140	180	20	105	100	140	73	14	182.5	155	265	
3040	50	75	53.5	14	M12	180	220	22	120	110	160	98	14	212.5	185	325	
3045	55	80	59.0	16	M12	200	250	24	135	130	180	108	14	242.5	215	344	
3050	60	90	64.0	18	M16	210	270	26	150	140	190	118	18	267.5	235	397	
3055	70	90	74.5	20	M16	240	290	28	160	160	210	118	18	292.5	265	425	
3060	80	110	85.5	22	M16	270	330	30	170	170	230	143	18	315	290	459	

MOTOR 1440 RPM		
F.S.	H.P.	Lh2
71	0.5	210
80	0.75/1.0	262
90	1.5/2.0	324
100	3.0	325
112	5.0	373
132	7.5/10.0	428
160	12.5/15.0/20.0	523
180	25.0/30.0	583

DOUBLE STAGE

MODEL	OUTPUT SHAFT					FOOT MOUNTING										OTHERS	
	D j6	L	H	K p9	M	B	E	T	C	F	J	G	S	Th	A	Lh1	
3005	19	30	21.5	6	M6	95	120	14	80	75	100	45	9	127.5	95	212	
3010	24	38	27.0	8	M6	110	140	16	90	85	115	55	11	145	110	227	
3020	28	40	31.0	8	M8	120	160	18	100	90	130	60	12	167.5	135	258	
3030	38	50	41.0	10	M10	140	180	20	105	100	140	73	14	182.5	155	303	
3040	50	75	53.5	14	M12	180	220	22	120	110	160	98	14	212.5	185	363	
3045	55	80	59.0	16	M12	200	250	24	135	130	180	108	14	242.5	215	384	
3050	60	90	64.0	18	M16	210	270	26	150	140	190	118	18	267.5	235	434	
3055	70	90	74.5	20	M16	240	290	28	160	160	210	118	18	292.5	265	470	
3060	80	110	85.5	22	M16	270	330	30	170	170	230	143	18	315	290	537	

TRIPPLE STAGE

MODEL	OUTPUT SHAFT					FOOT MOUNTING										OTHERS	
	D j6	L	H	K p9	M	B	E	T	C	F	J	G	S	Th	A	Lh1	
3005	19	30	21.5	6	M6	95	120	14	80	75	100	45	9	127.5	95	241	
3010	24	38	27.0	8	M6	110	140	16	90	85	115	55	11	145	110	260	
3020	28	40	31.0	8	M8	120	160	18	100	90	130	60	12	167.5	135	276	
3030	38	50	41.0	10	M10	140	180	20	105	100	140	73	14	182.5	155	325	
3040	50	75	53.5	14	M12	180	220	22	120	110	160	98	14	212.5	185	401	
3045	55	80	59.0	16	M12	200	250	24	135	130	180	108	14	242.5	215	430	
3050	60	90	64.0	18	M16	210	270	26	150	140	190	118	18	267.5	235	466	
3055	70	90	74.5	20	M16	240	290	28	160	160	210	118	18	292.5	265	526	
3060	80	110	85.5	22	M16	270	330	30	170	170	230	143	18	315	290	576	

FOUR STAGE

MODEL	OUTPUT SHAFT					FOOT MOUNTING										OTHERS	
	D j6	L	H	K p9	M	B	E	T	C	F	J	G	S	Th	A	Lh1	
3005	19	30	21.5	6	M6	95	120	14	80	75	100	45	9	127.5	95	270	
3010	24	38	27.0	8	M6	110	140	16	90	85	115	55	11	145	110	288	
3020	28	40	31.0	8	M8	120	160	18	100	90	130	60	12	167.5	135	309	
3030	38	50	41.0	10	M10	140	180	20	105	100	140	73	14	182.5	155	343	
3040	50	75	53.5	14	M12	180	220	22	120	110	160	98	14	212.5	185	413	
3045	55	80	59.0	16	M12	200	250	24	135	130	180	108	14	242.5	215	462	
3050	60	90	64.0	18	M16	210	270	26	150	140	190	118	18	267.5	235	496	
3055	70	90	74.5	20	M16	240	290	28	160	160	210	118	18	292.5	265	559	
3060	80	110	85.5	22	M16	270	330	30	170	170	230	143	18	315	290	607	

ALL DIMENSIONS ARE IN MM

1.6 SELECTION TABLE

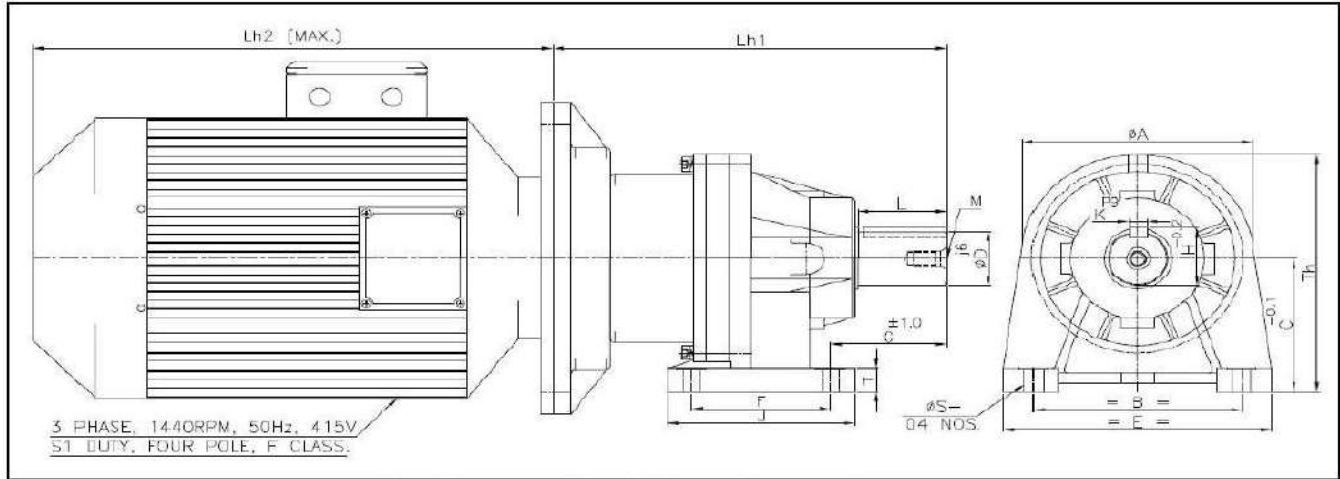

DIMENSIONS OF GEARED MOTOR FOOT MOUNTED

SINGLE STAGE

MODEL	OUTPUT SHAFT					FOOT MOUNTING										OTHERS	
	D/6	L	H	K p9	M	B	E	T	C	F	J	G	S	Th	A	Lh1	
1V095	90	120	95	25	M16	300	360	35	185	200	260	153.5	22	342.5	315	516	
1V99	95	130	100.0	25	M16	330	390	35	200	230	290	160.5	22	370	340	561	
1V10	110	170	116.0	28	M16	380	440	35	225	280	340	200	22	417.5	385	654	
1V11	120	180	127.0	32	M16	400	480	35	260	300	380	232.5	26	477.5	435	703	

MOTOR 1440 RPM		
F.S.	H.P.	Lh2
200	40.0	650
225	50.0/60.0	695
250	75.0	790
280	100.0/120.0	900

DOUBLE STAGE

MODEL	OUTPUT SHAFT					FOOT MOUNTING										OTHERS	
	D/6	L	H	K p9	M	B	E	T	C	F	J	G	S	Th	A	Lh1	
2V095	90	120	95	25	M16	300	360	35	185	200	260	153.5	22	342.5	315	585	
2V99	95	130	100.0	25	M16	330	390	35	200	230	290	160.5	22	370	340	625	
2V10	110	170	116.0	28	M16	380	440	35	225	280	340	200	22	417.5	385	741	
2V11	120	180	127.0	32	M16	400	480	35	260	300	380	232.5	26	477.5	435	805	

TRIPLE STAGE

MODEL	OUTPUT SHAFT					FOOT MOUNTING										OTHERS	
	D/6	L	H	K p9	M	B	E	T	C	F	J	G	S	Th	A	Lh1	
3V095	90	120	95	25	M16	300	360	35	185	200	260	153.5	22	342.5	315	630	
3V99	95	130	100.0	25	M16	330	390	35	200	230	290	160.5	22	370	340	707	
3V10	110	170	116.0	28	M16	380	440	35	225	280	340	200	22	417.5	385	795	
3V11	120	180	127.0	32	M16	400	480	35	260	300	380	232.5	26	477.5	435	884	

FOURTH STAGE

MODEL	OUTPUT SHAFT					FOOT MOUNTING										OTHERS	
	D/6	L	H	K p9	M	B	E	T	C	F	J	G	S	Th	A	Lh1	
3V095	90	120	95	25	M16	300	360	35	185	200	260	153.5	22	342.5	315	654	
3V99	95	130	100.0	25	M16	330	390	35	200	230	290	160.5	22	370	340	727	
3V10	110	170	116.0	28	M16	380	440	35	225	280	340	200	22	417.5	385	906	
3V11	120	180	127.0	32	M16	400	480	35	260	300	380	232.5	26	477.5	435	946	

ALL DIMENSIONS ARE IN MM



1.6 SELECTION TABLE

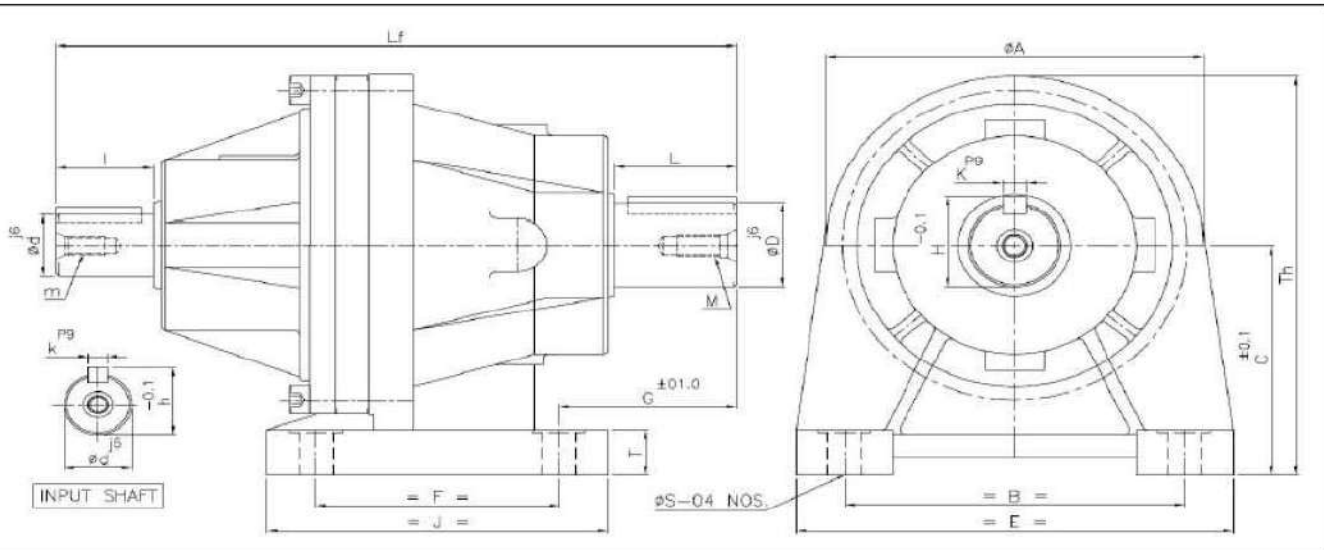

DIMENSIONS OF FOOT MOUNTED GEAR UNITS WITH FREE INPUT

SINGLE STAGE																					
MODEL	OUTPUT SHAFT					INPUT SHAFT					FOOT MOUNTING							OTHERS			
	Dj6	L	H	K p9	M	dj6	l	h	k p9	m	B	E	T	C	F	J	G	S	Th	A	Lf
3005	19	30	21.5	6	M6	14	20	16.0	5	M5	95	120	14	80	75	100	45	9	127.5	95	177
3010	24	38	27.0	8	M6	19	30	21.5	6	M8	110	140	16	90	85	115	55	11	145	110	215
3020	28	40	31.0	8	M8	24	35	27.0	8	M8	120	160	18	100	90	130	60	12	167.5	135	240
3030	38	50	41.0	10	M10	28	40	31.0	8	M8	140	180	20	105	100	140	73	14	182.5	155	280
3040	50	75	53.5	14	M12	38	50	41.0	10	M10	180	220	22	120	110	160	98	14	212.5	185	338
						42	55	45.0	12	M10											367
3050	60	90	64.0	18	M16	50	75	53.5	14	M12	210	270	26	150	140	190	118	18	267.5	235	409
3055	70	90	74.5	20	M16	50	75	53.5	14	M12	240	290	28	160	160	210	118	18	292.5	265	449
3060	80	110	85.5	22	M16	60	90	64.0	18	M12	270	330	30	170	170	230	143	18	315	290	503
DOUBLE STAGE																					
MODEL	OUTPUT SHAFT					INPUT SHAFT					FOOT MOUNTING							OTHERS			
	Dj6	L	H	K p9	M	dj6	l	h	k p9	m	B	E	T	C	F	J	G	S	Th	A	Lf
3005	19	30	21.5	6	M6	14	20	16.0	5	M5	95	120	14	80	75	100	45	9	127.5	95	206
3010	24	38	27.0	8	M6	14	20	16.0	5	M5	110	140	16	90	85	115	55	11	145	110	224
3020	28	40	31.0	8	M8	19	30	21.5	6	M8	120	160	18	100	90	130	60	12	167.5	135	263
3030	38	50	41.0	10	M10	24	35	27.0	8	M8	140	180	20	105	100	140	73	14	182.5	155	307
3040	50	75	53.5	14	M12	28	40	31.0	8	M8	180	220	22	120	110	160	98	14	212.5	185	368
3045	55	80	59.0	16	M12	28	40	31.0	8	M8	200	250	24	135	130	180	108	14	242.5	215	387
3050	60	90	64.0	18	M16	38	50	41.0	10	M10	210	270	26	150	140	190	118	18	267.5	235	432
3055	70	90	74.5	20	M16	42	50	41.0	10	M10	240	290	28	160	160	210	118	18	292.5	265	477
3060	80	110	85.5	22	M16	50	75	53.5	14	M12	270	330	30	170	170	230	143	18	315	290	555
TRIPPLE STAGE																					
MODEL	OUTPUT SHAFT					INPUT SHAFT					FOOT MOUNTING							OTHERS			
	Dj6	L	H	K p9	M	dj6	l	h	k p9	m	B	E	T	C	F	J	G	S	Th	A	Lf
3005	19	30	21.5	6	M6	14	20	16.0	5	M5	95	120	14	80	75	100	45	9	127.5	95	235
3010	24	38	27.0	8	M6	14	20	16.0	5	M5	110	140	16	90	85	115	55	11	145	110	253
3020	28	40	31.0	8	M8	14	20	16.0	5	M5	120	160	18	100	90	130	60	12	167.5	135	273
3030	38	50	41.0	10	M10	19	30	21.5	6	M8	140	180	20	105	100	140	73	14	182.5	155	330
3040	50	75	53.5	14	M12	24	35	27.0	8	M8	180	220	22	120	110	160	98	14	212.5	185	395
3045	55	80	59.0	16	M12	24	35	27.0	8	M8	200	250	24	135	130	180	108	14	242.5	215	421
3050	60	90	64.0	18	M16	28	40	31.0	8	M8	210	270	26	150	140	190	118	18	267.5	235	469
3055	70	90	74.5	20	M16	38	50	41.0	10	M10	240	290	28	160	160	210	118	18	292.5	265	525
3060	80	110	85.5	22	M16	38	50	41.0	10	M10	270	330	30	170	170	230	143	18	315	290	559
FOUR STAGE																					
MODEL	OUTPUT SHAFT					INPUT SHAFT					FOOT MOUNTING							OTHERS			
	Dj6	L	H	K p9	M	dj6	l	h	k p9	m	B	E	T	C	F	J	G	S	Th	A	Lf
3005	19	30	21.5	6	M6	14	20	16.0	5	M5	95	120	14	80	75	100	45	9	127.5	95	264
3010	24	38	27.0	8	M6	14	20	16.0	5	M5	110	140	16	90	85	115	55	11	145	110	282
3020	28	40	31.0	8	M8	14	20	16.0	5	M5	120	160	18	100	90	130	60	12	167.5	135	302
3030	38	50	41.0	10	M10	14	20	16.0	5	M5	140	180	20	105	100	140	73	14	182.5	155	336
3040	50	75	53.5	14	M12	19	30	21.5	6	M8	180	220	22	120	110	160	98	14	212.5	185	413
3045	55	80	59.0	16	M12	24	35	27.0	8	M8	200	250	24	135	130	180	108	14	242.5	215	461
3050	60	90	64.0	18	M16	24	35	27.0	8	M8	210	270	26	150	140	190	118	18	267.5	235	489
3055	70	90	74.5	20	M16	28	40	31.0	8	M8	240	290	28	160	160	210	118	18	292.5	265	544
3060	80	110	85.5	22	M16	28	40	31.0	8	M8	270	330	30	170	170	230	143	18	315	290	585

ALL DIMENSIONS ARE IN MM.

1.6 SELECTION TABLE

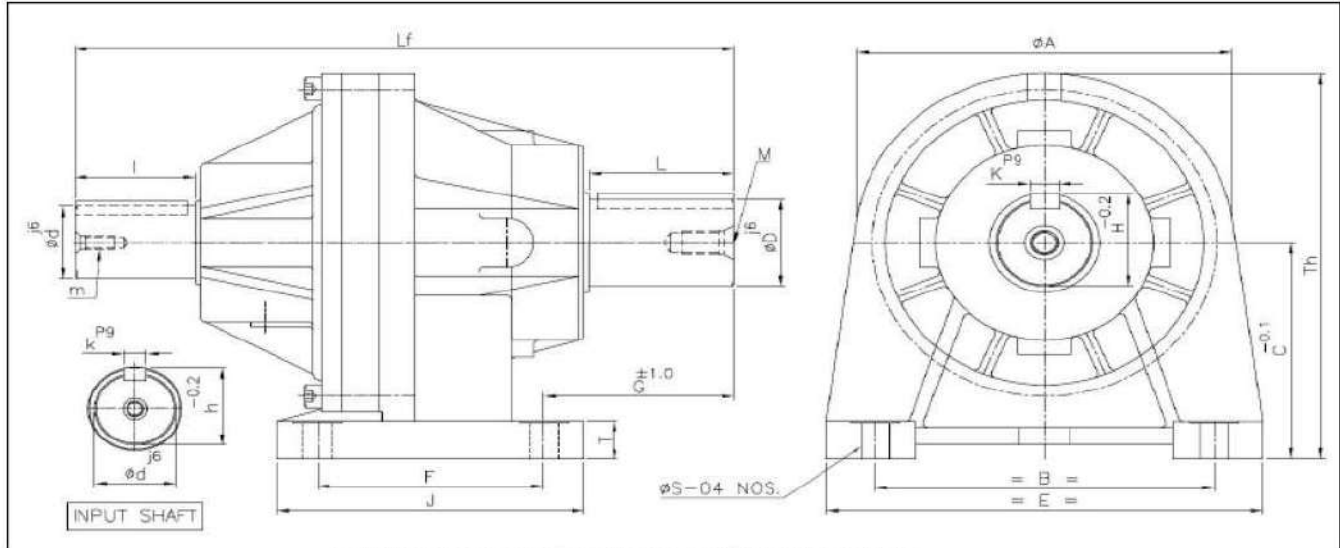

DIMENSIONS OF FOOT MOUNTED GEAR UNITS WITH FREE INPUT

SINGLE STAGE

MODEL	OUTPUT SHAFT					INPUT SHAFT					FOOT MOUNTING							OTHERS			
	D j6	L	H	K p9	M	d j6	l	h	k p9	m	B	E	T	C	F	J	G	S	Th	A	Lf
1V095	90	120	95	25	M16	65	90	69	18	M12	300	360	35	185	200	260	153.5	22	342.5	315	573
1V99	95	130	100.0	25	M16	70	90	75	20	M16	330	390	35	200	230	290	160.5	22	370	340	602
1V10	110	170	116.0	28	M16	80	110	86	20	M16	380	440	35	225	280	340	200	22	417.5	385	724
1V11	120	180	127.0	32	M16	75	100	80	20	M16	400	480	35	260	300	380	232.5	26	477.5	435	774

DOUBLE STAGE

MODEL	OUTPUT SHAFT					INPUT SHAFT					FOOT MOUNTING							OTHERS			
	D j6	L	D1	K p9	M	d j6	l	h	k p9	m	B	E	T	C	F	J	G	S	Th	A	Lf
2V095	90	120	95	25	M16	50	75	53.5	14	M12	300	360	35	185	200	260	153.5	22	342.5	315	609
2V99	95	130	100.0	25	M16	50	75	53.5	14	M12	330	390	35	200	230	290	160.5	22	370	340	613
2V10	110	170	116.0	28	M16	60	90	64.0	18	M12	380	440	35	225	280	340	200	22	417.5	385	744
2V11	120	180	127.0	32	M16	65	90	69	18	M12	400	480	35	260	300	380	232.5	26	477.5	435	819

TRIPLE STAGE

MODEL	OUTPUT SHAFT					INPUT SHAFT					FOOT MOUNTING							OTHERS			
	D j6	L	D1	K p9	M	d j6	l	h	k p9	m	B	E	T	C	F	J	G	S	Th	A	Lf
3V095	90	120	95	25	M16	42	55	45.0	12	M10	300	360	35	185	200	260	153.5	22	342.5	315	637
3V99	95	130	100.0	25	M16	50	75	53.5	14	M12	330	390	35	200	230	290	160.5	22	370	340	707
3V10	110	170	116.0	28	M16	50	75	53.5	14	M12	380	440	35	225	280	340	200	22	417.5	385	804
3V11	120	180	127.0	32	M16	60	90	64.0	18	M12	400	480	35	260	300	380	232.5	26	477.5	435	895

FOURTH STAGE

MODEL	OUTPUT SHAFT					INPUT SHAFT					FOOT MOUNTING							OTHERS			
	D j6	L	D1	K p9	M	d j6	l	h	k p9	m	B	E	T	C	F	J	G	S	Th	A	Lf
4V09	90	120	95	25	M16	38	50	41.0	10	M10	300	360	35	185	200	260	153.5	22	342.5	315	673
4V99	95	130	100.0	25	M16	42	55	45.0	12	M10	330	390	35	200	230	290	160.5	22	370	340	722
4V10	110	170	116.0	28	M16	50	75	53.5	14	M12	380	440	35	225	280	340	200	22	417.5	385	869
4V11	120	180	127.0	32	M16	50	75	53.5	14	M12	400	480	35	260	300	380	232.5	26	477.5	435	931

ALL DIMENSIONS ARE IN MM.

1.6 SELECTION TABLE

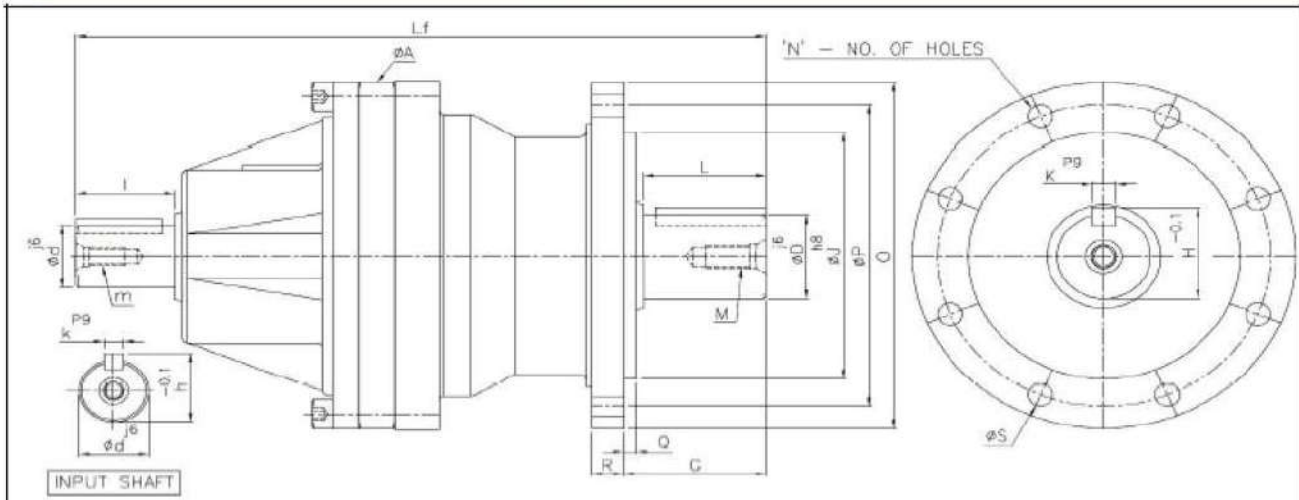

DIMENSIONS OF FLANGE MOUNTED GEAR UNITS WITH FREE INPUT

SINGLE STAGE

MODEL	OUTPUT SHAFT					INPUT SHAFT					FLANGE MOUNTING								OTHERS	
	D j6	L	H	K p9	M	d j6	l	h	k p9	m	J	O	Q	R	P	G	S	N	A	Lf
1V02	19	30	21.5	6	M6	14	20	16.0	5	M5	60	95	3	10	80	35	9	4	95	177
1V22	24	38	27.0	8	M6	19	30	21.5	6	M8	80	120	3	11	100	43	11	4	110	215
1V03	28	40	31.0	8	M8	24	35	27.0	8	M8	90	140	4	12	120	47	11	4	135	240
1V04	38	50	41.0	10	M10	28	40	31.0	8	M8	110	155	5	13	135	58	10	8	155	280
1V05	50	75	53.5	14	M12	38	50	41.0	10	M10	130	185	8	15	165	86	12	8	185	338
1V55	55	80	59.0	16	M12	42	55	45.0	12	M10	145	210	9	16	180	92	14	8	215	367
1V06	60	90	64.0	18	M16	50	75	53.5	14	M12	160	235	10	18	200	103	14	8	235	409
1V07	70	90	74.5	20	M16	50	75	53.5	14	M12	180	260	10	20	225	103	14	8	265	449
1V08	80	110	85.5	22	M16	60	90	64.0	18	M12	200	290	10	23	250	123	14	8	290	503
1V09	90	120	95	25	M16	65	90	69	18	M12	210	310	10	22	260	143.5	14	12	315	573

DOUBLE STAGE

MODEL	OUTPUT SHAFT					INPUT SHAFT					FLANGE MOUNTING								OTHERS	
	D j6	L	H	K p9	M	d j6	l	h	k p9	m	J	O	Q	R	P	G	S	N	A	Lf
2V02	19	30	21.5	6	M6	14	20	16.0	5	M5	60	95	3	10	80	35	9	4	95	206
2V22	24	38	27.0	8	M6	14	20	16.0	5	M5	80	120	3	11	100	43	11	4	110	224
2V03	28	40	31.0	8	M8	19	30	21.5	6	M8	90	140	4	12	120	47	11	4	135	263
2V04	38	50	41.0	10	M10	24	35	27.0	8	M8	110	155	5	13	135	58	10	8	155	307
2V05	50	75	53.5	14	M12	28	40	31.0	8	M8	130	185	8	15	165	86	12	8	185	368
2V55	55	80	59.0	16	M12	28	40	31.0	8	M8	145	210	9	16	180	92	14	8	215	387
2V06	60	90	64.0	18	M16	38	50	41.0	10	M10	160	235	10	18	200	103	14	8	235	432
2V07	70	90	74.5	20	M16	38	50	41.0	10	M10	180	260	10	20	225	103	14	8	265	477
2V08	80	110	85.5	22	M16	50	75	53.5	14	M12	200	290	10	23	250	123	14	8	290	555
2V09	90	120	95	25	M16	50	75	53.5	14	M12	210	310	10	22	260	143.5	14	12	315	609

TRIPLE STAGE:

MODEL	OUTPUT SHAFT					INPUT SHAFT					FLANGE MOUNTING								OTHERS	
	D j6	L	H	K p9	M	d j6	l	h	k p9	m	J	O	Q	R	P	G	S	N	A	Lf
3V02	19	30	21.5	6	M6	14	20	16.0	5	M5	60	95	3	10	80	35	9	4	95	235
3V22	24	38	27.0	8	M6	14	20	16.0	5	M5	80	120	3	11	100	43	11	4	110	253
3V03	28	40	31.0	8	M8	14	20	16.0	5	M5	90	140	4	12	120	47	11	4	135	273
3V04	38	50	41.0	10	M10	19	30	21.5	6	M8	110	155	5	13	135	58	10	8	155	330



1.6 SELECTION TABLE

3040	50	75	53.5	14	M12	24	35	27.0	8	M8	130	185	8	15	165	86	12	8	185	395
3045	55	80	59.0	16	M12	24	35	27.0	8	M8	145	210	9	16	180	92	14	8	215	421
3050	60	90	64.0	18	M16	28	40	31.0	8	M8	160	235	10	18	200	103	14	8	235	469
3055	70	90	74.5	20	M16	38	50	41.0	10	M10	180	260	10	20	225	103	14	8	265	525
3060	80	110	85.5	22	M16	38	50	41.0	10	M10	200	290	10	23	250	123	14	8	290	559
3065	90	120	95	25	M16	42	55	45.0	12	M10	210	310	10	22	260	143.5	14	12	315	637

FOUR STAGE

MODEL	OUTPUT SHAFT					INPUT SHAFT					FLANGE MOUNTING								OTHERS	
	D j6	L	H	K p9	M	d j6	l	h	kp9	m	J	O	Q	R	P	G	S	N	A	Lf
3005	19	30	21.5	6	M6	14	20	16.0	5	M5	60	95	3	10	80	35	9	4	95	264
3010	24	38	27.0	8	M6	14	20	16.0	5	M5	80	120	3	11	100	43	11	4	110	282
3020	28	40	31.0	8	M8	14	20	16.0	5	M5	90	140	4	12	120	47	11	4	135	302
3030	38	50	41.0	10	M10	14	20	16.0	5	M5	110	155	5	13	135	58	10	8	155	336
3040	50	75	53.5	14	M12	19	30	21.5	6	M8	130	185	8	15	165	86	12	8	185	413
3045	55	80	59.0	16	M12	24	35	27.0	8	M8	145	210	9	16	180	92	14	8	215	461
3050	60	90	64.0	18	M16	24	35	27.0	8	M8	160	235	10	18	200	103	14	8	235	489
3055	70	90	74.5	20	M16	28	40	31.0	8	M8	180	260	10	20	225	103	14	8	265	544
3060	80	110	85.5	22	M16	28	40	31.0	8	M8	200	290	10	23	250	123	14	8	290	585
3065	90	120	95	25	M16	38	50	41.0	10	M10	210	310	10	22	260	143.5	14	12	315	673

ALL DIMENSIONS ARE IN MM.





1.6 SELECTION TABLE

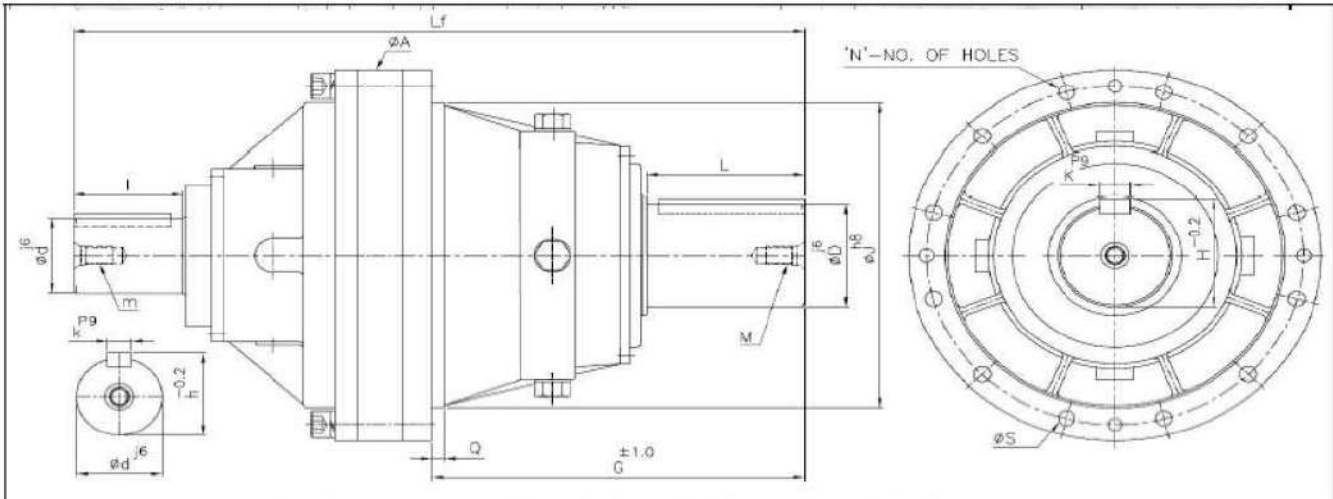

DIMENSIONS OF FLANGE MOUNTED GEAR UNITS WITH FREE INPUT

DIMENSIONS OF FLANGE MOUNTED GEAR UNITS WITH FREE INPUT																			
SINGLE STAGE		OUTPUT SHAFT					INPUT SHAFT					FLANGE MOUNTING					OTHERS		
MODEL	D j6	L	H	K p9	M	d j6	l	h	k p9	m	J	Q	P	G	S	N	A	Lf	
3070	95	130	100.0	25	M16	70	90	75	20	M16	280	10	310	306	17	12	340	602	
3080	110	170	116.0	28	M16	80	110	86	20	M16	320	12	350	378	17	12	385	724	
3090	120	180	127.0	32	M16	75	100	80	20	M16	360	16	400	406	17	16	435	774	
DOUBLE STAGE		OUTPUT SHAFT					INPUT SHAFT					FLANGE MOUNTING					OTHERS		
MODEL	D j6	L	H	K p9	M	d j6	l	h	k p9	m	J	Q	P	G	S	N	A	Lf	
3070	95	130	100.0	25	M16	50	75	53.5	14	M12	280	10	310	306	17	12	340	613	
3080	110	170	116.0	28	M16	60	90	64.0	18	M12	320	12	350	378	17	12	385	744	
3090	120	180	127.0	32	M16	65	90	69	18	M12	360	16	400	406	17	16	435	819	
TRIPPLE STAGE		OUTPUT SHAFT					INPUT SHAFT					FLANGE MOUNTING					OTHERS		
MODEL	D j6	L	H	K p9	M	d j6	l	h	k p9	m	J	Q	P	G	S	N	A	Lf	
3070	95	130	100.0	25	M16	50	75	53.5	14	M12	280	10	310	306	17	12	340	707	
3080	110	170	116.0	28	M16	50	75	53.5	14	M12	320	12	350	378	17	12	385	804	
3090	120	180	127.0	32	M16	60	90	64.0	18	M12	360	16	400	406	17	16	435	895	
FOUR STAGE		OUTPUT SHAFT					INPUT SHAFT					FLANGE MOUNTING					OTHERS		
MODEL	D j6	L	H	K p9	M	d j6	l	h	k p9	m	J	Q	P	G	S	N	A	Lf	
3070	95	130	100.0	25	M16	42	55	45.0	12	M10	280	10	310	306	17	12	340	722	
3080	110	170	116.0	28	M16	50	75	53.5	14	M12	320	12	350	378	17	12	385	869	
3090	120	180	127.0	32	M16	50	75	53.5	14	M12	360	16	400	406	17	16	435	931	

ALL DIMENSIONS ARE IN MM.



1.6 SELECTION TABLE

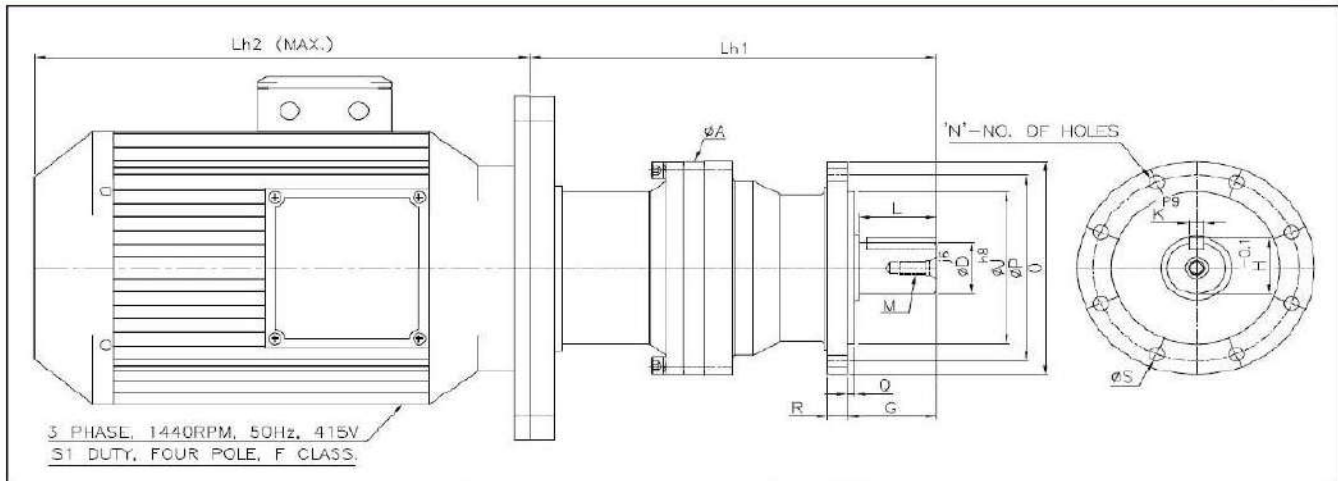

DIMENSIONS OF GEARED MOTOR FLANGE MOUNTED

SINGLE STAGE

MODEL	OUTPUT SHAFT					FLANGE MOUNTING								OTHERS	
	Dj6	L	H	K p9	M	J	O	Q	R	P	G	S	N	A	Lh1
1V02.	19	30	21.5	6	M6	60	95	3	10	80	35	9	4	95	183
1V22.	24	38	27.0	8	M6	80	120	3	11	100	43	11	4	110	203
1V03.	28	40	31.0	8	M8	90	140	4	12	120	47	11	4	135	236
1V04.	38	50	41.0	10	M10	110	155	5	13	135	58	10	8	155	265
1V05.	50	75	53.5	14	M12	130	185	8	15	165	86	12	8	185	325
1V55.	55	80	59.0	16	M12	145	210	9	16	180	92	14	8	215	344
1V06.	60	90	64.0	18	M16	160	235	10	18	200	103	14	8	235	397
1V07.	70	90	74.5	20	M16	180	260	10	20	225	103	14	8	265	425
1V08.	80	110	85.5	22	M16	200	290	10	23	250	123	14	8	290	459
1V09.	90	120	95	25	M16	210	310	10	22	260	143.5	14	12	315	516

MOTOR 1440 RPM		
F.S.	H.P.	Lh2
71	0.5	210
80	0.75/1.0	262
90	1.5/2.0	324
100	3.0	325
112	5.0	373
132	7.5/10.0	428
160	2.5/15.0/20	523
180	25.0/30.0	583
200	40.0	650

DOUBLE STAGE

MODEL	OUTPUT SHAFT					FLANGE MOUNTING								OTHERS	
	Dj6	L	H	K p9	M	J	O	Q	R	P	G	S	N	A	Lh1
2V02.	19	30	21.5	6	M6	60	95	3	10	80	35	9	4	95	212
2V22.	24	38	27.0	8	M6	80	120	3	11	100	43	11	4	110	227
2V03.	28	40	31.0	8	M8	90	140	4	12	120	47	11	4	135	258
2V04.	38	50	41.0	10	M10	110	155	5	13	135	58	10	8	155	303
2V05.	50	75	53.5	14	M12	130	185	8	15	165	86	12	8	185	363
2V55.	55	80	59.0	16	M12	145	210	9	16	180	92	14	8	215	384
2V06.	60	90	64.0	18	M16	160	235	10	18	200	103	14	8	235	434
2V07.	70	90	74.5	20	M16	180	260	10	20	225	103	14	8	265	470
2V08.	80	110	85.5	22	M16	200	290	10	23	250	123	14	8	290	537
2V09.	90	120	95	25	M16	210	310	10	22	260	143.5	14	12	315	585

TRIPLE STAGE

MODEL	OUTPUT SHAFT					FLANGE MOUNTING								OTHERS	
	Dj6	L	H	K p9	M	J	O	Q	R	P	G	S	N	A	Lh1
3V02.	19	30	21.5	6	M6	60	95	3	10	80	35	9	4	95	241
3V22.	24	38	27.0	8	M6	80	120	3	11	100	43	11	4	110	260
3V03.	28	40	31.0	8	M8	90	140	4	12	120	47	11	4	135	276
3V04.	38	50	41.0	10	M10	110	155	5	13	135	58	10	8	155	325
3V05.	50	75	53.5	14	M12	130	185	8	15	165	86	12	8	185	401
3V55.	55	80	59.0	16	M12	145	210	9	16	180	92	14	8	215	430
3V06.	60	90	64.0	18	M16	160	235	10	18	200	103	14	8	235	466
3V07.	70	90	74.5	20	M16	180	260	10	20	225	103	14	8	265	526
3V08.	80	110	85.5	22	M16	200	290	10	23	250	123	14	8	290	576
3V09.	90	120	95	25	M16	210	310	10	22	260	143.5	14	12	315	630

FOURTH STAGE

MODEL	OUTPUT SHAFT					FLANGE MOUNTING								OTHERS	
	Dj6	L	H	K p9	M	J	O	Q	R	P	G	S	N	A	Lh1
4V02.	19	30	21.5	6	M6	60	95	3	10	80	35	9	4	95	270
4V22.	24	38	27.0	8	M6	80	120	3	11	100	43	11	4	110	288
4V03.	28	40	31.0	8	M8	90	140	4	12	120	47	11	4	135	309
4V04.	38	50	41.0	10	M10	110	155	5	13	135	58	10	8	155	343
4V05.	50	75	53.5	14	M12	130	185	8	15	165	86	12	8	185	413
4V55.	55	80	59.0	16	M12	145	210	9	16	180	92	14	8	215	462
4V06.	60	90	64.0	18	M16	160	235	10	18	200	103	14	8	235	496
4V07.	70	90	74.5	20	M16	180	260	10	20	225	103	14	8	265	559
4V08.	80	110	85.5	22	M16	200	290	10	23	250	123	14	8	290	607
4V09.	90	120	95	25	M16	210	310	10	22	260	143.5	14	12	315	654

ALL DIMENSIONS ARE IN MM.

1.6 SELECTION TABLE

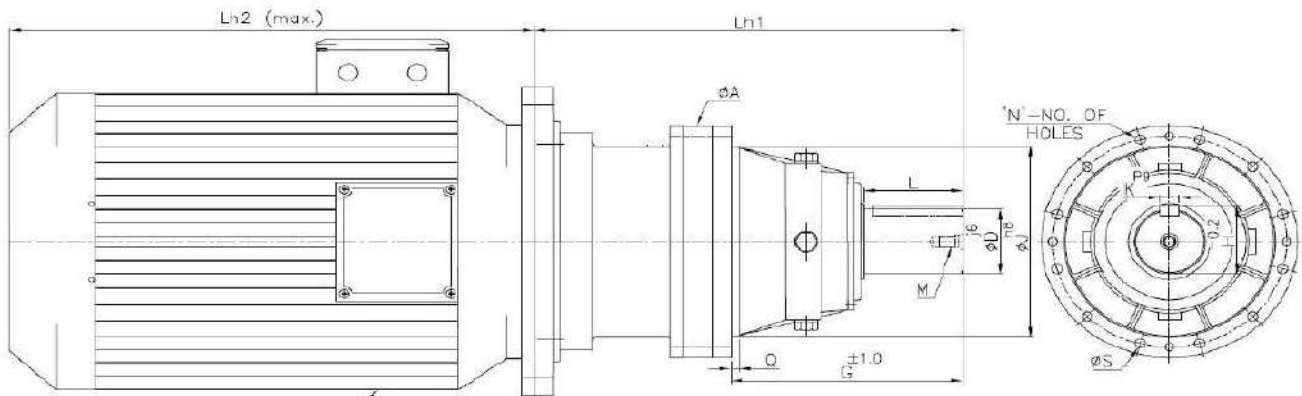

3 PHASE, 1440RPM, 50Hz, 415V
S1 DUTY, FOUR POLE, F CLASS.

DIMENSIONS OF GEARED MOTOR FLANGE MOUNTED

SINGLE STAGE

MODEL	OUTPUT SHAFT					FLANGE MOUNTING						OTHERS	
	D j6	L	H	K p9	M	J	Q	P	G	S	N	A	Lh1
1V09	95	130	100.0	25	M16	280	10	310	306	17	12	340	561
1V10	110	170	116.0	28	M16	320	12	350	378	17	12	385	654
1V11	120	180	127.0	32	M16	360	16	400	406	17	16	435	703

MOTOR 1440 RPM		
F.S.	H.P.	Lh2
225	50.0/60.0	695
250	75.0	790
280	100.0/120.0	900

DOUBLE STAGE

MODEL	OUTPUT SHAFT					FLANGE MOUNTING						OTHERS	
	D j6	L	H	K p9	M	J	Q	P	G	S	N	A	Lh1
2V09	95	130	100.0	25	M16	280	10	310	306	17	12	340	625
2V10	110	170	116.0	28	M16	320	12	350	378	17	12	385	741
2V11	120	180	127.0	32	M16	360	16	400	406	17	16	435	805

TRIPLE STAGE

MODEL	OUTPUT SHAFT					FLANGE MOUNTING						OTHERS	
	D j6	L	H	K p9	M	J	Q	P	G	S	N	A	Lh1
3V09	95	130	100.0	25	M16	280	10	310	306	17	12	340	707
3V10	110	170	116.0	28	M16	320	12	350	378	17	12	385	795
3V11	120	180	127.0	32	M16	360	16	400	406	17	16	435	884

FOURTH STAGE

MODEL	OUTPUT SHAFT					FLANGE MOUNTING						OTHERS	
	D j6	L	H	K p9	M	J	Q	P	G	S	N	A	Lh1
4V09	95	130	100.0	25	M16	280	10	310	306	17	12	340	727
4V10	110	170	116.0	28	M16	320	12	350	378	17	12	385	906
4V11	120	180	127.0	32	M16	360	16	400	406	17	16	435	946

ALL DIMENSIONS ARE IN MM.



MAINTENANCE

- Check the tightness of mounting bolts, after the initial 50 hours of operation.
- Change the oil first after 100 -150 hours operation.
- Subsequently, change the oil every 2000 - 3000 hours operation depending on application
- Alternatively change oil once in a year
- Check the oil level in the gearbox every month and top up as required
- Have a general checkup every day

STORAGE

Observe the following instructions to ensure correct storage of delivered products.

- Do not store outdoors, in areas exposed to weather or with excessive humidity.
- Always place boards in wood or other material between floor and products to avoid direct contact with the floor.
- For storage periods of over 60 days all machined surfaces such as flanges, shafts and couplings must be protected with a suitable anti-oxidation product (Mobilarma 248 or equivalent product).
- The following measures must be taken in receipt of products for which the expected storage period exceeds 6 months.

1) Cover outer machined parts and mating parts with grease to avoid oxidation.

2) Position the gearbox with the breather plug up and fill them with oil. Before use the gearbox should be filled with the proper amount of lubricant of the recommended type.

SUPPLY CONDITIONS

Gearboxes are supplied as follows:

- Ready for installation in the mounting position as specified purchase order.
- Dry inner parts are protected by the oil used for final testing. (without oil filled)
- Painted with colors. Mating surface are not painted
- Tested to in - house specifications
- Suitably packed
- Supplied with mounting nuts & bolts for IEC electric motors or hydraulic motors